

LEOK-3

Optics Experiment Kit

Instruction Manual



New Span Opto-Technology Inc.

16115 SW 117 Ave. A-15, Miami, FL 33177

Tel. (305) 235-6928

Fax. (305) 235-6328

E-mail: info@new-span.com

Web: www.new-span.com

CONTENTS

Introduction.....	3
Parts Included in the Kit	5
1. Light Sources	5
2. Mechanical Hardware	5
3. Optical Components.....	9
4. Other Parts	9
5. Optional Parts.....	9
Experiment Examples	10
1. Measuring the Focal Length of a Positive Thin Lens Using Auto-collimation.....	10
2. Measuring the Focal Length of a Positive Lens Using Displacement Method.....	12
3. Measuring Focal Length of an Eyepiece	14
4. Assembling a Microscope.....	16
5. Assembling a Telescope	18
6. Assembling a Slide Projector.....	20
7. Measuring the Nodal Locations and Focal Lengths of a Lens-Group	22
8. Assembling an Erect Imaging Telescope.....	24
9. Young's Double-Slit Interference.....	26
10. Interference of Fresnel's Biprism	28
11. Interference of Double Mirrors.....	30
12. Interference of Lloyd's Mirror.....	32
13. Interference of Newton's Ring.....	34
14. Fraunhofer Diffraction of Single Slit.....	36
15. Fraunhofer Diffraction of Single Circular Aperture.....	38
16. Fresnel Diffraction of Single Slit.....	40
17. Fresnel Diffraction of Single Circular Aperture	42
18. Fresnel Diffraction of a Sharp Edge	44
19. Analysing Polarization Status of Light Beams	45
20. Diffraction of a Grating	48
21. Grating Monochromator	50
22. Recording and Reconstructing Holograms	52
23. Making Holographic Gratings	54
24. Abbe Imaging Principle and Optical Spatial Filtering.....	56
25. Pseudo-Colour Encoding, Theta Modulation and Colour Composition.....	58
26. Assembling a Michelson Interferometer and Measuring Air Refractive Index.....	60
Laser safety and lab requirements:	63

Introduction

The LEOK-3 Optics Experiment Kit is developed for general physics education in universities and colleges. This kit provides complete set of optical and mechanical components as well as light sources, which can be conveniently assembled to construct experimental setups. Almost all optics experiments required in general physics education (e.g. geometrical, physical, and modern optics) can be constructed in sequence using these components. Through selecting and assembling the corresponding components into the setups by students themselves, their experimental skills and problem solving ability can be greatly enhanced.

LEOK-3 can be used to construct a total of 26 different experiments which can be grouped in five categories:

- Lens Measurements: Understanding and verifying lens equation and optical rays transform.
- Optical Instruments: Understanding the working principle and operation method of common lab optical instruments.
- Interference Phenomena: Understanding interference theory, observing various interference patterns generated by different sources, and grasping one precise measurement method based on optical interference.
- Diffraction Phenomena: Understanding diffraction effects, observing various diffraction patterns generated by different apertures.
- Analysis of Polarization:
- Fourier Optics and Holography: Understanding principles of advanced optics and their applications.

Experiment examples list

Measuring the focal length of a positive thin lens using auto-collimation

Measuring the focal length of a positive thin lens using displacement method

Measuring the focal length of an eyepiece

Assembling a microscope

Assembling a telescope

Assembling a slide projector

Measuring the nodal locations and focal length of a lens-group

Assembling an erect imaging telescope

Young's double-slit interference

Interference of Fresnel's biprism

Interference of double mirrors

Interference of Lloyd's mirror

Interference of Newton Ring

Franhoffer diffraction of a single slit

Franhoffer diffraction of a single circular aperture

Fresnel diffraction of single slit

Fresnel diffraction of single circular aperture
Fresnel diffraction of a sharp edge
Analysing polarization status of light beams
Diffraction of a grating
Assembling a Littrow-type grating spectrometer
Recording and reconstructing holograms.
Making holographic gratings.
Abbe imaging principle and optical spatial filtering.
Pseudo-colour encoding, theta modulation and colour composition.
Assembling a Michelson interferometer and measuring air refractive index

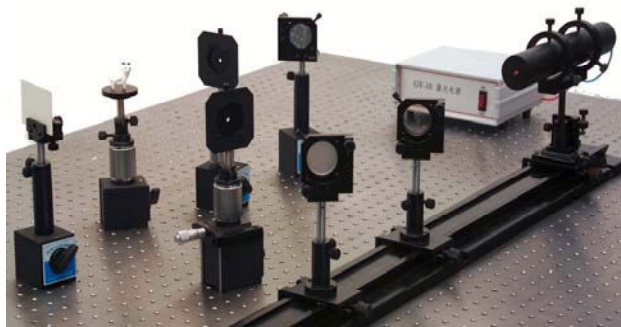



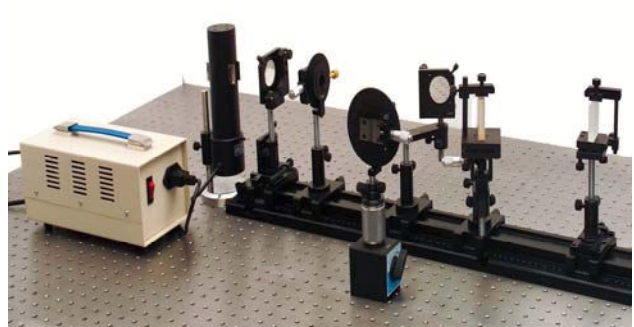

Setup of Hologram Recording



Setup of a Grating Spectrometer

Parts Included in the Kit







1. Light Sources



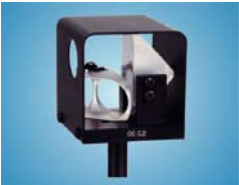





<p>Low Pressure Mercury Lamp (LLE-1) 20W with power supply (100 to 120, 220 to 240VAC, 50/60Hz)</p> <p><i>1 piece</i></p>		<p>Low Pressure Sodium Lamp (LLE-2) 20W with power supply (100 to 120, 220 to 240VAC, 50/60Hz)</p> <p><i>1 piece</i></p>	
<p>Bromine Tungsten Lamp (LLC-4) 6V/15 W with power supply (100 to 120, 220 to 240VAC, 50/60Hz)</p> <p><i>1 piece</i></p>		<p>He-Ne Laser (LLL-2) 1.5mW with power supply (100 to 120, 220 to 240VAC, 50/60Hz)</p> <p><i>1 piece</i></p>	
<p>Small Illuminating Lamp (LLC-6) 3VDC (100 to 120, 220 to 240VAC, 50/60Hz)</p> <p><i>1 piece</i></p>			

2. Mechanical Hardware

<p>Two-Axis Stage (LEPO-2) X translation stage (10mm travel and 0.01mm resolution) Z-adjustable (30mm) with a magnetic base</p> <p><i>1 piece</i></p>		<p>Z-Adjustable Post Holder (LEPO-3) Travel 30mm with a magnetic base</p> <p><i>1 piece</i></p>	
<p>Magnetic Base (LEPO-4) With post holder</p> <p><i>3 pieces</i></p>		<p>Aperture Adjustable Holder (LEPO-6) Variable Φ10-50 mm with two directions tiltable</p> <p><i>1 piece</i></p>	

<p>Two-Axis Tilttable Holder (LEPO-8) $\Phi 40$ mm for mounting optical components such as lenses, mirrors, gratings, reticle, et al <i>2 pieces</i></p>		<p>Lens Holder (LEPO-9) Optical diameter: $\Phi 40$mm <i>2 pieces</i></p>	
<p>Adapter Piece (LEPO-10) Two lenses can't be placed too close to each other, owing to the size limit of the magnetic stands. Using this piece, the two lenses can stand closer <i>1 piece</i></p>		<p>Grating/Prism Table (LEPO-11) 30° Z-axis rotation, two directions tilttable <i>1 piece</i></p>	
<p>Prism Table (LEPO-12) with two directions tilttable <i>1 piece</i></p>		<p>Plate Holder A (LEPO-13) One direction tilttable <i>2 pieces</i></p>	
<p>White Screen (LEPO-14) Uniform diffusing painting <i>1 piece</i></p>		<p>Object Screen (LEPO-15) Symmetrical triangle holes uniform diffusing painting <i>1 piece</i></p>	
<p>Iris Diaphragm (LEPO-16) 0-14 mm adjustable <i>1 piece</i></p>		<p>3-D Adjustable Holder (LEPO-17) One axis translation (10mm) and two-axis tilttable. <i>1 piece</i></p>	
<p>Plate Holder B (LEPO-19) with two directions tilttable <i>1 piece</i></p>		<p>Aperture Adjustable Bar Clamp (LEPO-20) 30-50mm, with two tilttable directions, for mounting tube-type components <i>1 piece</i></p>	
<p>Loading Table (LEPO-21) <i>1 piece</i></p>		<p>Multi-pinhole Disc Assembly (LEPO-24) $\Phi 0.10, 0.15, 0.20, 0.30, 0.50, 0.60, 1.00, 2.00$ mm <i>1 piece</i></p>	

<p>Single-Side Adjustable Slit (LEPO-28) Slit width 0–2 mm, slit direction tiltable within $\pm 5^\circ$</p> <p><i>1 piece</i></p>		<p>Lens Group Holder (LEPO-29) Movable on rail for nodal measurement</p> <p><i>1 piece</i></p>	
<p>Erecting prism (LEPO-31) Used for inverting image in two directions</p> <p><i>1 piece</i></p>		<p>Ruler (LEPO-34) Used for experiment of measuring telescope's magnification</p> <p><i>1 piece</i></p>	
<p>DMM Holder (LEPO-37) * DMM is abbreviation of Direct Measuring Microscope</p> <p><i>1 piece</i></p>		<p>Newton Ring Assembly (LEPO-38)</p> <p><i>1 piece</i></p>	
<p>Newton Ring Holder (LEPO-39)</p> <p><i>1 piece</i></p>		<p>Spring Clip (LEPO-40) Used for fastening small white screen and plane samples</p> <p><i>1 piece</i></p>	
<p>Spectral Filter (LEPO-41) Used for Abbe's image formation and experiment in space filtering.</p> <p><i>1 piece</i></p>		<p>Single-sided Rotary Slit (LEPO-42) The slit is variable from 0-5mm on one side and rotatable within $\pm 5^\circ$</p> <p><i>1 piece</i></p>	
<p>Biprism Holder (LEPO-43) It allows to attach a biprism or other optical component to it, and rotate within $\pm 5^\circ$.</p> <p><i>1 piece</i></p>		<p>Laser Holder (LEPO-44) Allows to attach a He-Ne laser and other tubular part to it.</p> <p><i>1 piece</i></p>	
<p>Ground Glass Screen (LEPO-45) It has an effective aperture of $\Phi 117\text{mm}$, used for Abbe's theory of image formation and experiment of space filtering.</p> <p><i>1 piece</i></p>		<p>45° Glass Holder (LEPO-47) Used for microscope magnification experiment.</p> <p><i>1 piece</i></p>	

<p>Optical Goniometer (LEPO-49) Used for polarization caused by reflection and refraction, measuring Brewster angle at accuracy of 0.5°.</p> <p><i>1 piece</i></p>		<p>Iceland Crystal Rotary Holder (LEPO-50)</p> <p>Used for crystal birefringence experiment.</p> <p><i>1 piece</i></p>	
<p>Paper Clip (LEPO-51) Used for Abbe's theory of image formation and experiment of space filtering.</p> <p><i>1 piece</i></p>		<p>Polaroid Holder (LEPO-52) Used for polarized light experiment.</p> <p><i>2 pieces</i></p>	
<p>1-D Carrier with Holder (LEPO-54-2) Used with optical rail</p> <p><i>3 piece</i></p>		<p>2-D Carrier with Holder (LEPO-55-3) Used with optical rail</p> <p><i>2 piece</i></p>	
<p>3-D Carrier with Holder (LEPO-54-2) Used with optical rail</p> <p><i>2 piece</i></p>			
<p>Optical Rail with Carriers (LEPO-54) 1.0 meter long dovetail rail (LEPO-54-1) used with carriers</p>			

3. Optical Components

Mounted Lenses: $f = 4.5, 6.2, 15, 45, 50, 70, 150, 190, 225, 300, -100\text{mm}$, 1 piece each
 Mounted Cemented Lenses: $f = 29, 105\text{mm}$, 1 piece each
 Mounted Flat Mirrors: $\Phi 36\text{mm}$, 2 pieces
 Mounted Beam Splitter: $\Phi 30\text{mm}$, 5:5 and 7:3, 1 piece each
 Mounted Flaring Grating (at 500nm): 1200 l/mm, $30 \times 30\text{mm}$, 1 piece
 Mounted Transmission Grating: 20 l/mm, 1 piece
 Mounted 2-Dimensional Grating: 20 l/mm, 1 piece
 Mounted Waveplates: $\frac{1}{4}\lambda, \frac{1}{2}\lambda$ @632.8nm, $\Phi 10\text{mm}$, 1 piece each
 Equilateral Prism: 60° , 1 piece
 Mounted Reticles: 1/5, 1/10mm, 1 piece each
 Mounted Millimetre Ruler: 30mm long, 1 piece
 Mounted Double-Wedge Prism (biprism), 1 piece
 Mounted Polarizer: $\Phi 20\text{mm}$, 2 pieces
 Spherical Mirror: $f = 300\text{mm}$, 1 piece
 Multiple Slits Plate: groups in 2, 3, 4, 5 slits, 1 piece
 Transmission Character, 1 piece
 Zero Order Filter, 1 piece
 Fresnel Bimirror (LEPO-32): 1 piece
 Modulation Plate, 1 piece
 Small object for holography, 1 piece
 Lloyd Mirror (LEPO-33), 1 piece
 Double-slit, 1 piece
 White screen: $70 \times 50\text{mm}$, 1 piece
 Projector Slide, 1 piece
 Ground Glass, 4 pieces



4. Other Parts

Description	Part No.	Qty	Note
Holographic Plate	GS-I	1 Box	12 pcs, 9x24cm each, glass 530 ~ 700nm, peak @630nm
Air Chamber and Pump with Gauge	LEPO-55	1	3 ~ 40Kpa/20 ~ 300mmHg used for air index measurement

5. Optional Parts

Description	Part No.	Qty	Note
Parts Holder Stand	LEPO-57	1	each stand can hold 20 parts

* Note: Above parts are subject to change without notice.

Experiment Examples

1. Measuring the Focal Length of a Positive Thin Lens Using Auto-collimation

Objective

Comprehend and grasp the principle and method of measuring the focal length of a lens using auto-collimation.

Experimental Setup (Figure 1-2)

- 1: Bromine Tungsten Lamp S (LLC-4)
- 2: Object Screen P (LEPO-15)
- 3: Convex Lens L ($f=190$ mm)
- 4: Two-axis Tilt Holder (LEPO-8)

- 5: Flat Mirror M
- 6: 3-D Adjustable Post Holder (LEPO-17)
- 7: Optical Rail (LEPO-54)

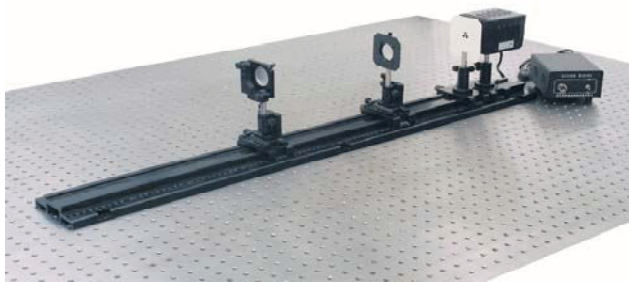

Figure 1-1

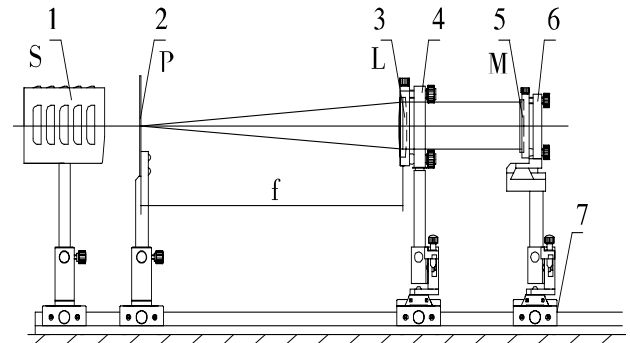

Figure 1-2

Principle

Under the condition of paraxial rays, the Gauss equation of thin lens imaging is:

$$\frac{f'}{s'} + \frac{f}{s} = 1 \quad (1-1)$$

Where s is the distance of an object from the thin lens, s' is the distance of a conjugate image of the object from the thin lens, and f' is focal length. Then, we get:

$$f = -f' = -\frac{s's}{s-s'} \quad (1-2)$$

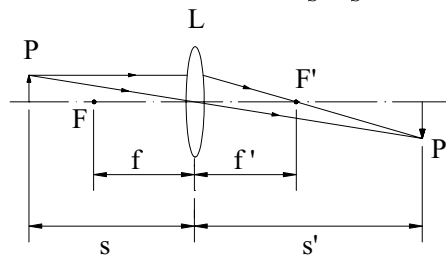

Figure 1-3

Here, we use another approach to calculate f , i.e., auto-collimation method.

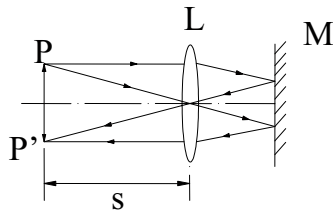

Figure 1-4

As shown in Figure 1-4, place an object P on one side of the convex lens. When it is just in the focal plane, any ray from the object is refracted by the lens would change into parallel ray. After reflected by the plane mirror and again refracted by the lens, it still converged in focal plane of the lens. The distance between lens and object is the focal length of the lens: $f = s$

Experimental Procedures:

- 1) Refer to Figure 1-2, align all components in same height along a line;
- 2) Move lens L back and forth, till a clear image of the object on P is observed on the back surface of P ;
- 3) Adjust axis of mirror M , and finely move L , till the image is clearest and same size as the object (so that the object and its image fills up a whole circular region);
- 4) Write down the locations of P and L as s_1 and s_2 ;
- 5) Respectively reverse P and L to exchange their front and back surfaces, repeat steps 1-4;
- 6) Write down new locations of P and L as s_3 and s_4 ;
- 7) Calculate focal length:

$$f_1' = s_2 - s_1, \quad f_2' = s_4 - s_3,$$

$$f' = \frac{f_1' + f_2'}{2}.$$

Note: The point source on the front focal point will be collimated from the lens, and one collimated beam will be focused on back focal point.

2. Measuring the Focal Length of a Positive Lens Using Displacement Method

Objective

Comprehend and grasp the principle and method of measuring lens focal length with displacement approach, verify “lens equation”.

Experimental Setup (Figure 2-2)

- 1: Bromine Tungsten Lamp S (LLC-4)
- 2: Object Screen P (LEPO-15)
- 3: Convex Lens L ($f'=190$ mm)

- 4: Two-axis Tilt Holder (LEPO-8)
- 5: White Screen H (LEPO-14)
- 6: Optical Rail (LEPO-54)

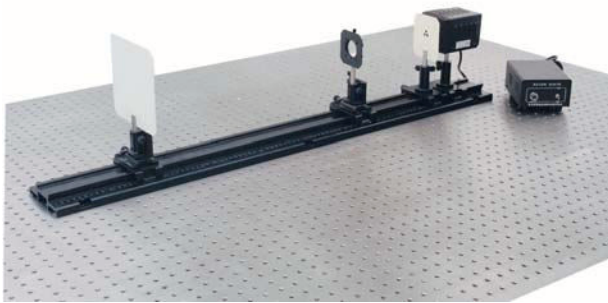

Figure 2-1

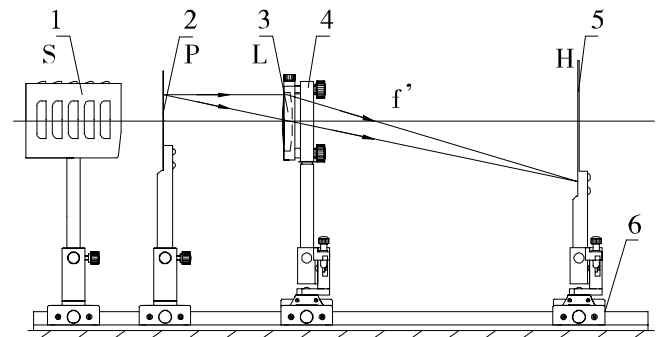

Figure 2-2

Principle

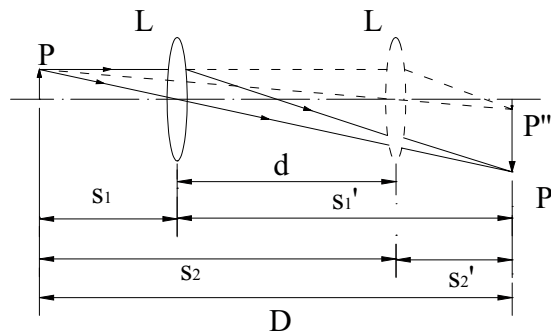

Figure 2-3

In the first experiment we measure the focal length by using auto-collimation. Because the lens centre is not easy to be determined, the error is big. So we take a new method, i.e., displacement method.

When the distance between the object and the screen is longer than four times the focal length, we move the lens, and get a clear image twice at different points. We have the two equations:

$$\frac{1}{f} = \frac{1}{s_1} + \frac{1}{s_1'} \quad (2-1)$$

$$\frac{1}{f} = \frac{1}{s_2} + \frac{1}{s_2'} \quad (2-2)$$

Using the conditions: $D = s_1 + s_1' = s_2 + s_2', s_2 = s_1 + d, s_1' = s_2' + d,$

We can get the formula:

$$f = \frac{D^2 - d^2}{4D} \quad (2-3)$$

This method is more accurate than the previous method.

Experimental Procedures:

- 1) Refer to Figure 2-2, align all components in same height along the optical rail;
- 2) Move lens L back and forth, till a clear magnified image of object on P observed on screen H . Write down the positions of object P , lens L , and image screen H as D_1, d_1 and D_2 ;
- 3) Fix P and H , move L far away from P till a clear magnified image observed on H , write down position of lens L as d_2 ;
- 4) Reverse P, L , and H , repeat steps 1-3, obtain another two locations of lens L as d_3 and d_4 ;
- 5) Calculate focal length:

$$f_1 = \frac{(D_2 - D_1)^2 - (d_2 - d_1)^2}{4(D_2 - D_1)}$$

$$f_2 = \frac{(D_2 - D_1)^2 - (d_4 - d_3)^2}{4(D_2 - D_1)}$$

$$f = \frac{1}{2}(f_1 + f_2)$$

Note: Use “lens equation” to derive the above formula.

3. Measuring Focal Length of an Eyepiece

Objective

Comprehend and grasp the principle and methodology of obtaining eyepiece lens focal length by means of measuring magnification between image and object, further verify “lens equation”.

Note: DMM is the abbreviation of Direct Measurement Microscope
ME is the abbreviation of Microscope Eyepiece

Experimental Setup (Figure 3-2)

- 1: Bromine Tungsten Lamp S (LLC-4)
- 2: Reticle M (1/10 mm)
- 3: Biprism Holder (LEPO-43)
- 4: To Be Measured Eyepiece Lens L_e ($f_e=29\text{mm}$)

- 5: Two-axis Tilt Holder (LEPO-8)
- 6: Eyepiece of DMM ME
- 7: DMM Holder (LEPO-37)
- 8: Optical Rail (LEPO-54)
- * Adaptor Piece (LEPO-10) might be used

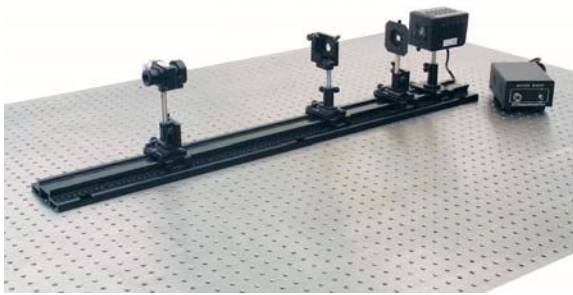

Figure 3-1

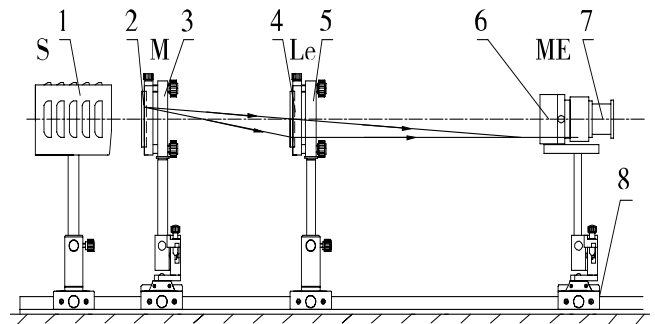

Figure 3-2

Principle

Abbe's method: An image of an object is formed on a screen by a lens. Leaving the lens fixed, the object is moved to a new position and the image screen moved until it again receives a focused image. If the separation between the two object position is Δs , and if the transverse magnifications of the image are m_1 and m_2 respectively. Then, according to the Gauss equation, we have:

$$\frac{f'}{s_1'} + \frac{f}{s_1} = 1 \quad (3-1)$$

$$\frac{f'}{s_2'} + \frac{f}{s_2} = 1 \quad (3-2)$$

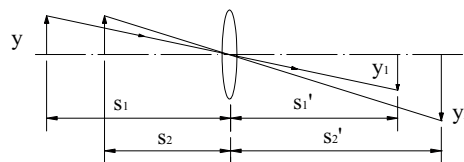

Figure 3-3

Where, s_1 and s_2 are the distances of an object from a thin lens, s_1' and s_2' are the distances of its conjugate images from the thin lens, as shown in Figure 3-3.

Using the conditions:

$$m_1 = \frac{y_1}{y} = \frac{s_1'}{s_1} \quad m_2 = \frac{y_2}{y} = \frac{s_2'}{s_2}$$

$$\Delta s = s_1 - s_2 \quad f' = -f$$

By (3-1) and (3-2)

$$\frac{f}{m_1}(1 + m_1) = s_1 \quad \frac{f}{m_2}(1 + m_2) = s_2$$

So the focal length of the lens is given by

$$f = \frac{m_1 m_2}{m_2 - m_1} \Delta s$$

Experimental Procedures:

- 1) Refer to Figure 3-2, align all components in same height along a line;
- 2) Fix reticle plate F and microscope eyepiece (ME), slowly move lens Le away from F , till a clear magnified image of F observed in ME and no viewing difference with standard reticle scale of ME ;
- 3) Measure image width (1/10 mm scale) of the reticle F with the standard reticle in ME , calculate magnification m_1 , write down the locations of ME and Le as a_1 and b_1 respectively;
- 4) Move ME away 30 to 40 mm, then slowly move Le forward to F , till a clear magnified image of F is observed again in ME and no viewing difference with standard reticle scale of ME ;
- 5) Measure this new image width, calculate magnification m_2 , and write down the locations of ME and Le as a_2 and b_2 respectively;
- 6) Calculate ME focal length:

Magnification: $m_i = (\text{image size})/(\text{actual size}), i = 1, 2$

Distance change of two images: $\Delta s = (a_2 - a_1) + (b_2 - b_1)$

ME focal length: $f_{ME} = \frac{m_1 m_2}{m_2 - m_1} \Delta s$

4. Assembling a Microscope

Objective

Comprehend the working principle and the construction of a microscope, grasp method of microscope adjustment, and measure the system magnification.

Experimental Setup (Figure 4-2)

- 1: Small Illuminating Lamp S (LLC-6)
- 2: Plate Holder A (LEPO-13)
- 3: Reticle M_1 ($1/10$ mm)
- 4: Two-axis Tilt Holder (LEPO-8)
- 5: Objective Lens L_o ($f'_o=29$ mm)
- 6: 3-D Adjustable Holder (LEPO-17)
- 7: Adapter Piece (LEPO-10)
- 8: Two-axis Tilt Holder (LEPO-8)

- 9: Eyepiece Lens L_e ($f'_e=45$ mm)
 - 10: Beam Splitter (BS) and 45° Glass Holder (LEPO-47)
 - 11: Optical Rail (LEPO-54)
 - 12: Two-axis Stages (LEPO-2)
 - 13: Biprism Holder (LEPO-43)
 - 14: Millimetre Ruler M_2 ($l = 30$ mm)
- * Bromine Tungsten Lamp S (LLC-4) can be used to illuminate Millimetre Ruler

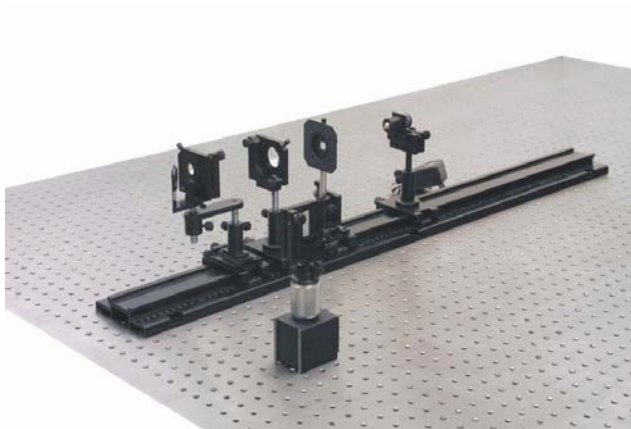

Figure 4-1

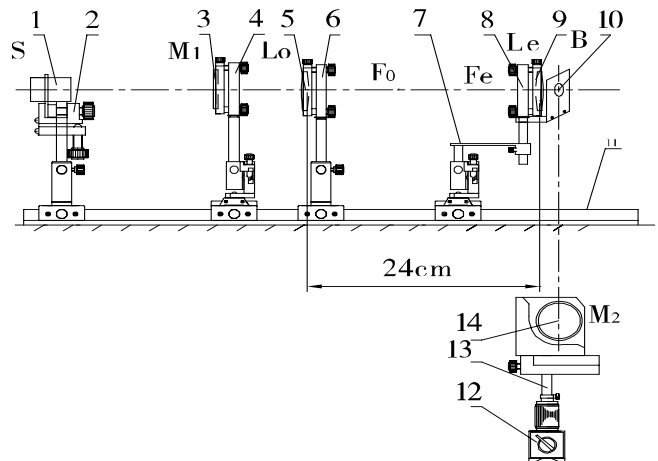

Figure 4-2

Principle

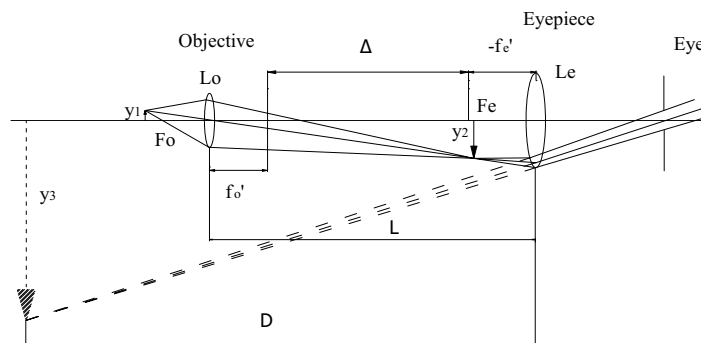

Figure 4-3

As shown in Figure 4-3, the optical system of the microscope employs an objective with a short focal length and a magnifying eyepiece. The magnification is achieved in two stages as shown. The microscope objective forms an enlarged image of the object in a position suitable for viewing through the eyepiece; the magnification through the objective is given by

$$y_2/y_1 = \Delta / f_o' \quad (4-1)$$

Generally, the focal length of eyepiece f_e' is much less than D , so

$$y_3/y_2 \approx D / f_e' \quad (4-2)$$

Then we get the total magnification:

$$M = \frac{y_3}{y_1} = \frac{y_3}{y_2} \frac{y_2}{y_1} = \frac{D\Delta}{f_o' f_e'} \quad (4-3)$$

Where Δ is the distance between the focus of objective and the focus of eyepiece, f_o' is the focal length of objective and f_e' is that of eyepiece.

Experimental Procedures:

- 1) Refer to Figures 4-2, align all components in same height;
- 2) Fix interval between L_o and L_e as $D = 180$ mm;
- 3) Move reticle plate M_1 back and forth, till clear M_1 virtual image observed behind L_e ;
- 4) Put the beam splitter (BS) behind L_e and set 45° angle with respect to the optical axis;
- 5) Put the millimetre ruler M_2 beside the BS (vertical to main optical axis along the rail) and approximate 250 mm distance from B (*in diagram*);
- 6) Viewing behind B by one eye, finely rotate the BS angle to overlap the microscope virtual image from M_1 and the M_2 image from the BS reflection;
- 7) Finely adjust M_1 to eliminate viewing difference between the two images;
- 8) Count the scale amount a in M_1 image included in the range of 30 mm of image M_2 ;
- 9) Calculate the measured magnification of the assembled microscope and its theoretical magnification:

$$\text{Measured Magnification: } M = \frac{30 \times 10}{a}$$

$$\text{Theoretical Magnification: } M' = \frac{25\Delta}{f_o' f_e'}, \text{ where, } \Delta = D - (f_o' + f_e')$$

5. Assembling a Telescope

Objective

Comprehend the working principle and construction of a telescope, grasp methods of adjustment and use, measure system magnification.

Experimental Setup (Figure 5-2)

- | | |
|--|--|
| 1: Ruler (LEPO-34) | 4: Eyepiece Lens L_e ($f'_e=29$ mm) |
| 2: Objective Lens L_o ($f'_o=225$ mm) | 5: Two-axis Tilt Holder (LEPO-8) |
| 3: Two-axis Tilt Holder (LEPO-8) | 6: Optical Rail (LEPO-54) |

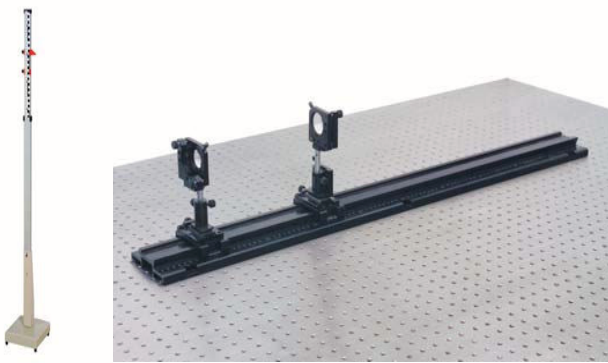

Figure 5-1

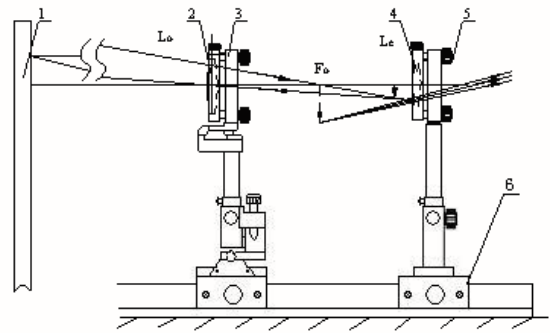

Figure 5-2

Principle

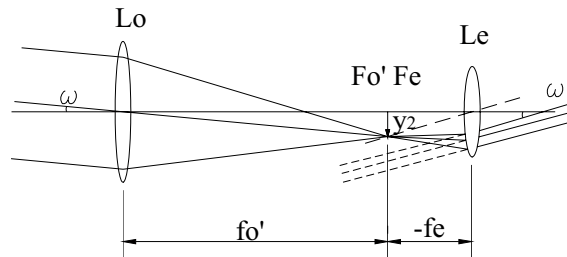

Figure 5-3

The magnifying power of an instrument used for observation of objects at infinity is defined as the angular magnification at the pupils because the angles are very small:

$$M = \frac{\tan \omega'}{\tan \omega} = \frac{\omega'}{\omega} = \frac{f'_o}{f'_e} \quad (5-1)$$

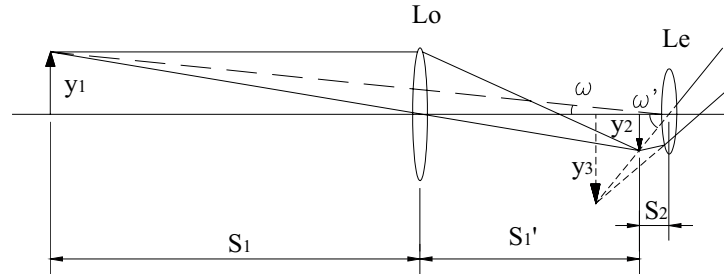

Figure 5-4

As shown in Figure 5-4, when observing an object at quasi-infinity, the power of magnification is:

$$M = \frac{\tan \omega'}{\tan \omega} = \frac{y_2 / s_2}{y_1 / (s_1 + s_1' + s_2)} \quad (5-2)$$

And $y_2/y_1 = s_1'/s_1$

Therefore,

$$M = s_1'(s_1 + s_1' + s_2) / s_1 s_2 \quad (5-3)$$

Experimental Procedures:

- 1) Refer to Figure 5-2, align all components in same height, set the distance between object (a ruler) and eyepiece lens Le on the experimental table as long as possible;
- 2) Move objective lens Lo back and forth, behind Le , use one eye to observe the image of the ruler till it clear;
- 3) Use another eye to directly observe the scale lines on the ruler, count how many scale lines (amount a) in the telescope image are covered by 30 lines on the ruler image directly to the eye;
- 4) Use a white screen H (LEPO-14) to find the image of the ruler through Lo , respectively write down the locations of the ruler, Lo , H , and Le as a , b , c , and d ;
- 5) Calculate measured magnification of the assembled telescope and its theoretical value:

$$\text{Measured Magnification: } M = \frac{30}{a}$$

$$\text{Theoretical Magnification: } M = s_1'(s_1 + s_1' + s_2) / s_1 s_2$$

$$\text{Where } s_1 = b - a, s_1' = c - b, s_2 = d - c$$

6. Assembling a Slide Projector

Objective

Comprehend the working principle of a slide projector and the function of its condenser, grasp adjustment methods for the projection optical system, and understand illuminating condition for achieving a uniform light field on the screen (Kohler illumination).

Experimental Setup (Figure 6-2)

- | | |
|---|---|
| 1: Bromine Tungsten Lamp S (LLC-4) | 6: Projection Lens L_2 ($f'_2=150$ mm) |
| 2: Condenser Lens L_1 ($f'_1=50$ mm) | 7: 3-D Adjustable Holder (LEPO-17) |
| 3: Two-axis Tilt Holder (LEPO-8) | 8: White Screen (LEPO-14) |
| 4: Projector Slide P | 9: Optical Rail (LEPO-54) |
| 5: Plate Holder A (LEPO-13) | * Ground glass on LLC-4 is not used and Adaptor Piece (LEPO-10) might be used |

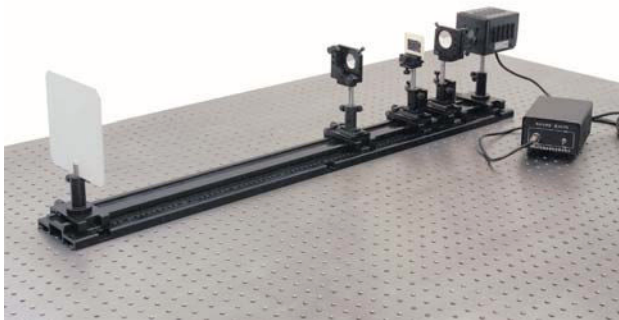

Figure 6-1

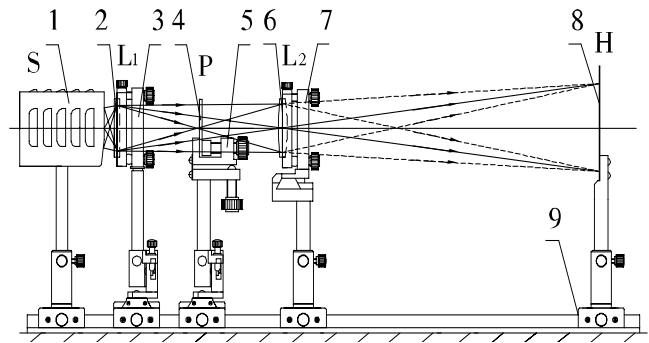

Figure 6-2

Principle

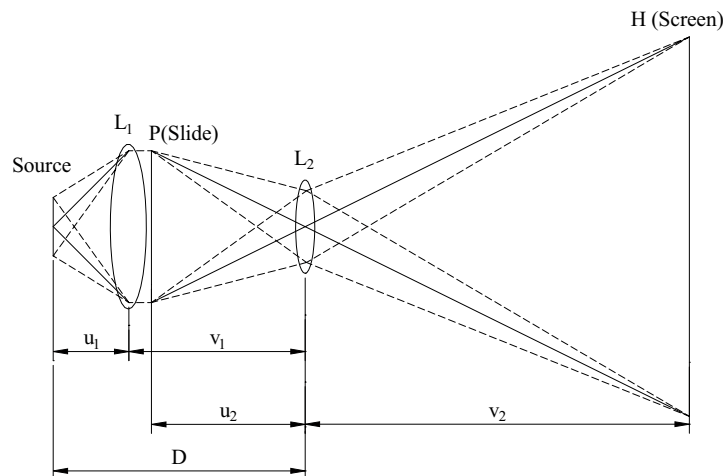

Figure 6-3

As shown in Figure 6-3 shows, L_1 is a condenser, L_2 is a projection lens. A slide is just behind L_1 (we can assume $v_1 = u_2$). If the magnification of slide projector is M , the length of slide projector is D , and the focal length of L_1 and L_2 are f_1 and f_2 respectively.

By $M = v_2 / u_2$, $1 / f_2 = 1 / u_2 + 1 / v_2$, we can get

$$f_2 = \frac{1}{M+1} v_2 \quad (6-1)$$

By $D = u_1 + v_1$, $v_1 = u_2$, $1 / f_1 = 1 / u_1 + 1 / v_1$, we can get

$$f_1 = \frac{v_2}{M} - \frac{1}{D} \left(\frac{v_2}{M} \right)^2 \quad (6-2)$$

Experimental Procedures:

- 1) Refer to Figure 6-2, align all components in same height, set the distance between L_2 and screen H about 0.8 m;
- 2) Move slide P back and forth, till a clear image (imaged by L_2) is observed on H ;
- 3) Fix condenser close to P , remove P , move light source S back and forth, till the image of S by L_1 is clear on L_2 aperture plane;
- 4) Put back slide P at its pervious location, observe the brightness and uniformity of the projected image on the screen;
- 5) Remove L_1 , observe the brightness and uniformity of the projected image again, and recognize the function of L_1 .

7. Measuring the Nodal Locations and Focal Lengths of a Lens-Group

Objective: Comprehend characteristics of nodes of a lens-group, and grasp the method for measuring nodal locations.

Experimental Setup (Figure 7-2)

- 1: Bromine Tungsten Lamp S (LLC-4)
- 2: Millimetre Ruler
- 3: Biprism Holder (LEPO-43)
- 4: Collimating Lens L_0 ($f'_0=150$ mm)
- 5: Two-axis Tilt Holder (LEPO-8)

- 6: Lens Group L_1 and L_2 ($f'_1=300$ mm, $f'_2=190$ mm)
- 7: Lens Group Holder (LEPO-29)
- 8: DMM Holder (LEPO-37)
- 9: Eyepiece of DMM
- 10: Optical Rail (LEPO-54)
- * Others include flat mirror

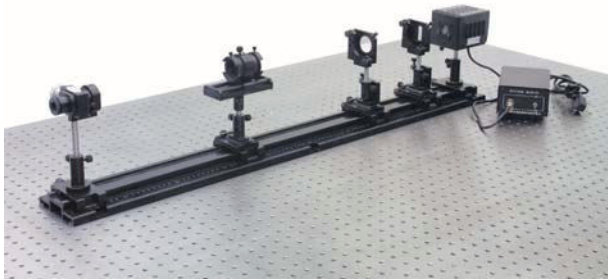

Figure 7-1

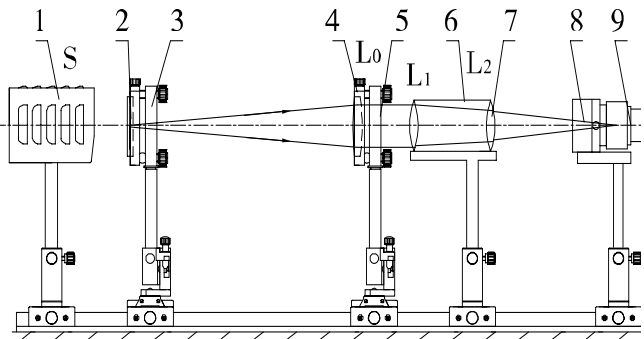

Figure 7-2

Principle

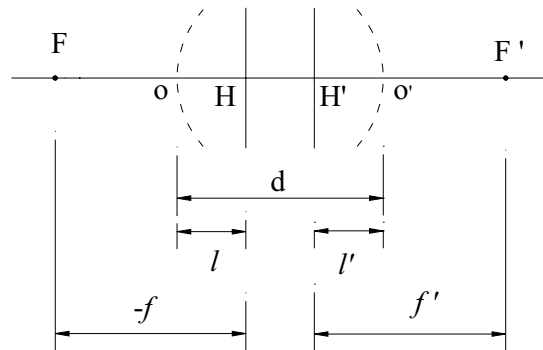

Figure 7-3

There are six cardinal points on the axis of a lens system. F and F' are the focal length, H and H' are the principal points and dot lines are the surface of the lens system (Figure 7-3). N and N' are the nodal points (Figure 7-4) of the lens system. We can get the cardinal points by measuring f, f', l, l' and thickness d of the lens system.

The nodal points are identical to the principal points when the front and rear media share the same refractive index. When a light ray enters the front of the lens system and toward the front nodal point, it will exit directly from the rear nodal point at the same angle to the axis as the entrance ray.

For lens systems in air, the nodal points coincide with the principal points and so we can use them to locate the principal planes and find the effective focal length.

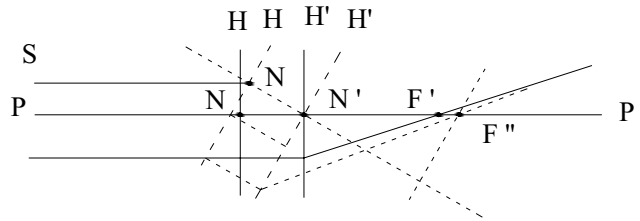

Figure 7-4

Let a parallel beam shoot into the lens system, it will be converged at the effective focal point F' of the lens system. When the lens system rotate small angle just through the nodal point N' , the beam will still converge on the ray axis and does not have any transverse displacement.

Experimental Procedures:

- 1) Adjust the distance between millimetre ruler and collimating lens L_o to obtain a collimated beam from L_o with the assistance of a flat mirror (self-alignment method);
- 2) Put in a lens group and eyepiece of DMM, align them to the same height as other optical parts, move microscope eyepiece back and forth to find a clear image of millimetre ruler;
- 3) Move the lens group back and forth along the rail guide on the nodal holder, and simultaneously move the microscope eyepiece to follow the clear image. After each movement of the lens group, rotate it around its vertical axis, till the ruler image in the microscope doesn't have transversal displacement when the lens group rotates. At this moment, the image space node of the lens group is located on the rotation axis of the lens group holder.
- 4) Replace microscope eyepiece with a white screen, observe the ruler image, respectively write down the locations of the screen and lens group holder on the optical rail as a and b . Also write down the deviation amount d of the central location of the lens group (marked under the lens group tube) from the rotation axis of the holder;
- 5) Reverse lens-group holder 180° , repeat step 3 and 4, obtain another set data of a' , b' and d' ;
- 6) Data processing: The distance of image space node and object space node from the lens group centre are d and d' , the focal lengths of the lens group in image space and object space are $f = a - b$ and $f' = a' - b'$ respectively;
- 7) Make a 1:1 drawing to show the measured lens group and relative positions of the cardinal points of the lens group.

8. Assembling an Erect Imaging Telescope

Objective

Comprehend the principle and function of using double right angle prisms to erect the image in a telescope system, further grasp skills for adjusting a telescope.

Experimental Setup (Figure 8-2)

- 1: Ruler (LEPO-34)
- 2: Objective Lens L_o ($f_o'=225$ mm)
- 3: 3-D Adjustable Holder (LEPO-17)
- 4: Erecting Prism (LEPO-31)
- 5: Eyepiece Lens L_e ($f_e'=45$ mm)
- 6: Two-axis Tilt Holder (LEPO-8)
- 7: Optical Rail (LEPO-54)
- * Adaptor Piece (LEPO-10) might be used

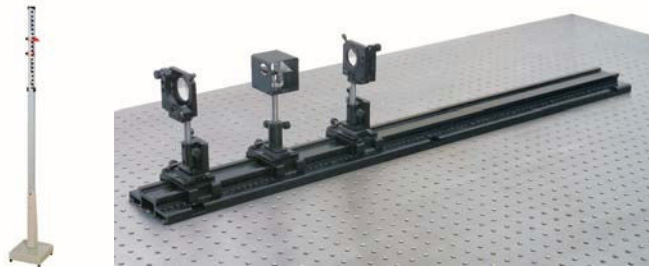

Figure 8-1

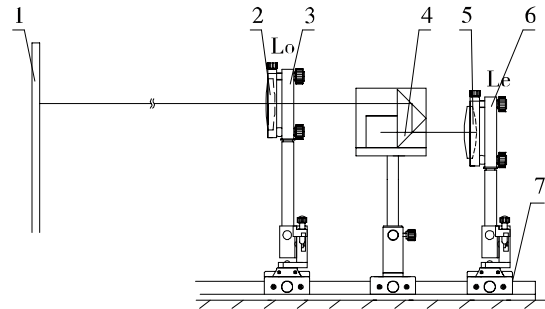

Figure 8-2

Principle

In the previous experiment example of assembling a telescope, everything is inverted. However, we need a right-side-up picture. In the mid 19th century, an Italian named Porro designed a telescope with two prisms set at right angle each other between the objective lens and the eyepiece. This arrangement not only erects and reverses the image, but also folds the light path, resulting in a shorter and more manageable instrument.

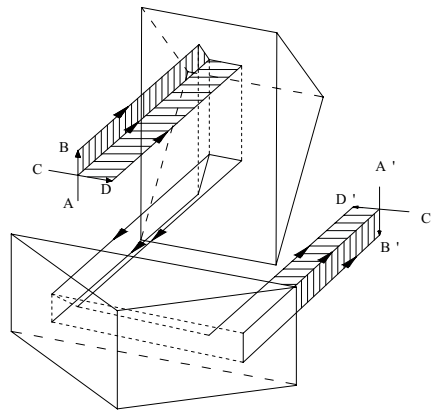

Figure 8-3

The structure of double right angle prism (Porro Prism) is shown in Figure 8-3, which can turn the image formed by objective lens right side up.

Experimental Procedures:

- 1) Refer to Figure 8-2, align all components in same height, set the distance between the ruler and L_e on the optical table as far as possible;
- 2) Assemble a reverse image telescope system using L_o and L_e , finely focusing the object, remember the image direction status;
- 3) Insert a double right angle prism at the front of the intermediate image of lens L_o , and let their primary cross-sections in horizontal axis and vertical axis respectively;
- 4) Adjust the height and location of L_e , till a clear image of the object can be observed, compare this image with the image without prisms (this one should be erect).

9. Young's Double-Slit Interference

Objective

To observe double-slit interference phenomena and measure the wavelength of light.

Experimental Setup (Figure 9-1)

- | | |
|--|-----------------------------|
| 1: Sodium Lamp (LLE-2, including Aperture Diaphragm) | 6: Lens L_2 ($f'=50$ mm) |
| 2: Lens L_1 ($f'=50$ mm) | 7: Biprism Holder (LEPO-43) |
| 3: Two-axis Tilt Holder (LEPO-8) | 8: Double-slit Plate |
| 4: Single-sided Adjustable Slit (LEPO-28) | 9: Adapter Piece (LEPO-10) |
| 5: Lens Holder (LEPO-9, including Diaphragm) | 10: DMM Holder (LEPO-37) |
| | 11: Eyepiece of DMM |
| | 12: Optical Rail (LEPO-54) |

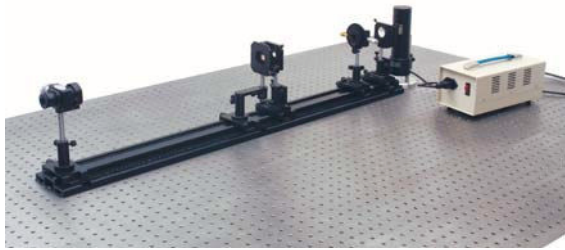

Figure 9-1

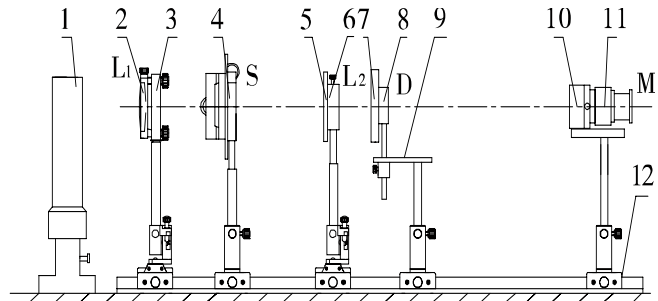

Figure 9-2

Principle

In order to get an interference pattern, the two beams leaving from the slits must have same frequency and a definite phase relation. Generally, most light sources except lasers cannot satisfy this condition. In 1801, Thomas Young allowed a single, narrow beam of light to fall on two narrow, closely spaced slits. He placed a viewing screen opposite to the slits. Where the light from the two slits struck the screen, a regular dark and black pattern appeared. When first performed, Young's experiment offered an important evidence for the wave nature of light. The method of Young's double-slit interference is showed in Figure 9-3.

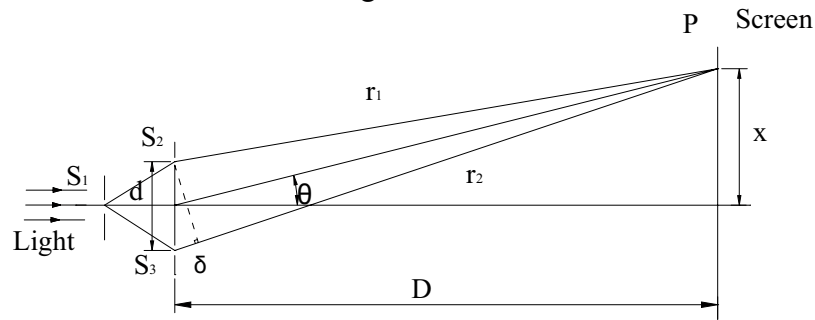

Figure 9-3

In this way, the light emits from S_2 and S_3 has a definite phase relation because the secondary wave sources from the same wave surface S_1 are always coherent.

The light path difference (d is the distance between the two slits of the double-slit plate):

$$\delta = r_2 - r_1 \approx d \sin \theta \approx d \tan \theta = d \frac{x}{D} \quad (9-1)$$

If the path distance from a particular point on the screen to the two slits is equivalent to half of the wavelength (or multiples thereof) of the light, then complete destructive interference will occur at that point, and a dark spot will be observed in the interference pattern.

$$\delta = d \frac{x}{D} = \pm(2k+1) \frac{\lambda}{2} \quad (\text{Dark interference fringes}) \quad (9-2)$$

Conversely, if the path difference to a particular point is equivalent to an integer multiple of the wavelength of the light, then complete constructive interference will occur, and a bright spot will appear on the screen.

$$\delta = d \frac{x}{D} = \pm k\lambda \quad (\text{Bright interference fringes}) \quad (9-3)$$

So the distance between two nearest dark fringe (or bright fringe) is:

$$\Delta x = \frac{D}{d} \lambda \quad (9-4)$$

In this formula Δx and D can be measured, so when we know one of d and λ we can calculate another one. In this experiment if a laser is used as the source instead of Sodium lamp, the experiment will be easier and the interference fringes will be observed more obviously.

Experimental Procedures:

- 1) Refer to Figure 9-2, align all components in same height;
- 2) Focus the aperture of the light source onto the single slit by a lens, the key to the success of this experiment is to align the slit directions of both single slit and double-slit parallel;
- 3) Use a direct measurement microscope to observe double-slit interference pattern, equal-interval bright/dark fringe pairs will be observed;
- 4) Measure fringe interval e between two adjacent fringes using direct measurement microscope, also measure the distance L between double-slit plate and the microscope;

Use the known value of double-slit interval t and expression of $e = \frac{L\lambda}{t}$, so that the wavelength λ of the illumination light can be obtained.

10. Interference of Fresnel's Biprism

Objective

To observe Fresnel's biprism interference phenomena and measure the wavelength of light.

Experimental Setup (Figure 10-2)

- | | |
|--|---------------------------------|
| 1: Sodium Lamp (LLE-2, including Aperture Diaphragm) | 5: Double-wedge Prism (Biprism) |
| 2: Lens L_1 ($f' = 50$ mm) | 6: Biprism Holder (LEPO-43) |
| 3: Two-axis Tilt Holder (LEPO-8) | 7: DMM Holder (LEPO-37) |
| 4: Single-side Adjustable Slit (LEPO-28) | 8: Eyepiece of DMM |
| | 9: Optical Rail (LEPO-54) |

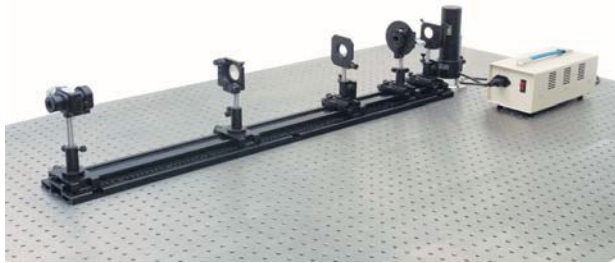

Figure 10-1

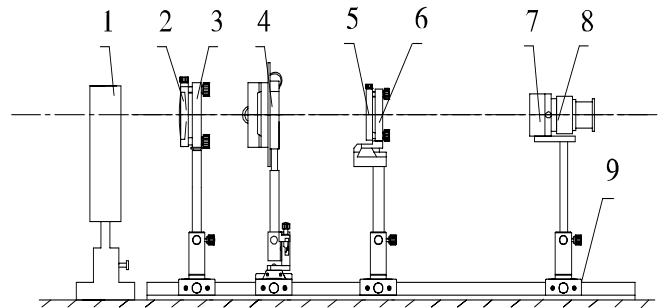

Figure 10-2

Principle

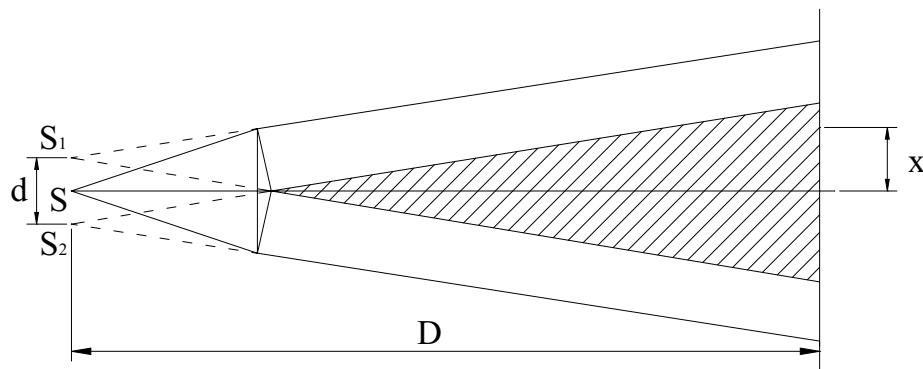

Figure 10-3

Fresnel's biprism consists of two equal prisms of small refracting angle placed together as shown in Figure 10-3. A pencil of light from a point source S is divided by refraction into two overlapping pencils. The prisms form two virtual images, S_1 and S_2 of light source S . They take the same effect as the two slits in previous Young's experiment.

So we have the formulae as follows:

$$d \frac{x}{D} = \pm(2k+1) \frac{\lambda}{2} \quad (\text{Dark interference fringes}) \quad (10-1)$$

$$d \frac{x}{D} = \pm k\lambda \quad (\text{Bright interference fringes}) \quad (10-2)$$

$$\Delta x = \frac{D}{d} \lambda \quad (10-3)$$

Where Δx is the distance between two adjacent dark fringes (or bright fringes), d is the distance between the two virtual images S_1 and S_2 . It cannot be measured directly. But we can put a lens behind the biprism and measure the distance between the images of S_1 and S_2 by eyepiece of DMM, and then calculate d by the Gauss equation.

Experimental Procedures:

- 1) Refer to Figure 10-2, align all components in same height, set the distances between components approximately around the distances shown in the Figure;
- 2) Focus the aperture of the light source onto the single slit by a lens. The key to the success of this experiment is to align the directions of single slit and the double-edge of biprism parallel;
- 3) Use a direct measurement microscope to observe biprism interference pattern, hence, equal-interval bright/dark fringe pairs will be observed;
- 4) Measure the fringe interval Δx between two adjacent fringes using a direct measurement microscope, and measure the distance L between the single slit plate and the microscope;
- 5) To obtain the interval d between the two virtual line light sources generated by the Fresnel's biprism, put a lens L_2 ($f=190$ mm) behind the biprism to image the two virtual line sources into real images. Move the direct measurement microscope to the real images plane and measure the distance between the two real images as d' , by the use of object-image relationship of lens imaging (lens equation) to obtain d ;
- 6) Use d , Δx , D and expression of $e = \frac{L\lambda}{t}$, so that the wavelength λ of the illumination light can be obtained.

11. Interference of Double Mirrors

Objective

To observe of double mirrors interference phenomena and measure the wavelength of light.

Experimental Setup (Figure 11-2)

- | | |
|--|-----------------------------|
| 1: Sodium Lamp (LLE-2, including Aperture Diaphragm) | 6: Plate Holder A (LEPO-13) |
| 2: Lens L_1 ($f' = 50$ mm) | 7: DMM Holder (LEPO-37) |
| 3: Two-axis Tilt Holder (LEPO-8) | 8: Eyepiece of DMM |
| 4: Single-side Adjustable Slit (LEPO-28) | 9: Two-Axis Stages (LEPO-2) |
| 5: Double Mirrors Assembly (LEPO-32) | 10: Optical Rail (LEPO-54) |

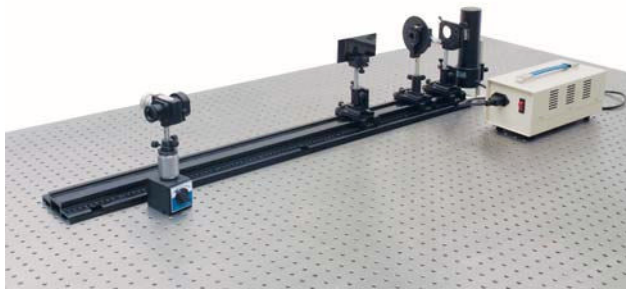

Figure 11-1

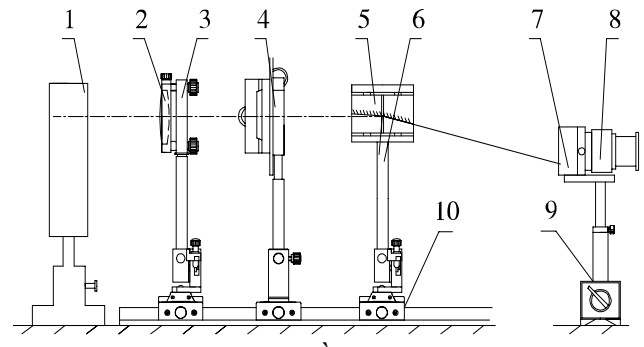

Figure 11-2

Principle

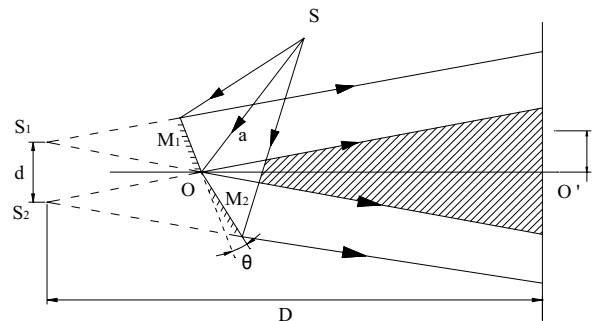

Figure 11-3

Fresnel's Mirrors have the structure as shown in Figure 11-3. Two plane mirrors M_1 and M_2 with a very small variable angle. Light from point source S is incident on the two mirrors, and the reflection form two virtual images S_1 , S_2 of light source S , which act as coherent sources. If $SO = a$, then

$$S_1O = S_2O = a$$

The distance between S_1 and S_2 is

$$d = 2a \sin \theta \quad (11-1)$$

where θ is the angle between the mirrors.

As in Young's experiment, we get the formulae:

$$d \frac{x}{D} = \pm(2k+1) \frac{\lambda}{2} \quad (\text{Dark interference fringes}) \quad (11-2)$$

$$d \frac{x}{D} = \pm k \lambda \quad (\text{Bright interference fringes}) \quad (11-3)$$

$$\lambda = \frac{d}{D} \Delta x = \frac{2a \sin \theta}{a \cos \theta + OO'} \Delta x \approx \frac{2a \theta}{a + OO''} \Delta x \quad (11-4)$$

Experimental Procedures:

- 1) The key to the success of this experiment is to align the directions of the two mirrors by adjusting the three screws on the back of one mirror, so as to guarantee the normal of two mirrors in one plane, and there is an appropriate angle between them;
- 2) To fulfil the above condition, use a small laser beam to illuminate the adjacent area of the two mirrors (half beam on each mirror), and two reflected beam spots can be observed on the far field screen. By fine adjustment of the three screws on the back of one mirror, the input beam and the two reflected beams is in a one plane. The intersection angle θ of the two mirrors can be obtained by calculating the ratio of the two beam spots separation on the screen and the distance between screen and the mirrors (here we align them at about 0.5 degree);
- 3) Refer to Figure 11-2, align all components in same height.
- 4) Focus the light source onto the single slit by a lens, rotate single slit direction and align it parallel to the mirrors' intersection;
- 5) Use direct measurement microscope to observe the interference pattern which have equal-interval bright/dark fringe pairs;
- 6) Measure the fringe interval Δx between two adjacent fringes using the direct measurement microscope and the path length D from single slit to the microscope via the intersection of the two mirrors;
- 7) To obtain the interval d between the two virtual images S_1, S_2 of the slit light source S using the double mirrors, multiply the double angle of two mirrors 2θ (measured in above step 2) by the distance a between the single slit and the mirrors;
- 8) Use $d, \Delta x, D$ and expression of $\lambda = \frac{d}{D} \Delta x$, so that the wavelength λ of the illumination light can be obtained.

12. Interference of Lloyd's Mirror

Objective

To observe Lloyd's mirror interference phenomena and measure the wavelength of light

Experimental Setup (Figure 12-2)

- | | |
|--|-----------------------------|
| 1: Sodium Lamp (LLE-2, including Aperture Diaphragm) | 6: Plate Holder A (LEPO-13) |
| 2: Lens L_1 ($f'=50$ mm) | 7: DMM Holder (LEPO-37) |
| 3: Two-axis Tilt Holder (LEPO-8) | 8: Eyepiece of DMM |
| 4: Single-side Adjustable Slit (LEPO-28) | 9: Two-Axis Stages (LEPO-2) |
| 5: Lloyd's Mirror (LEPO-33) | 10: Optical Rail (LEPO-54) |

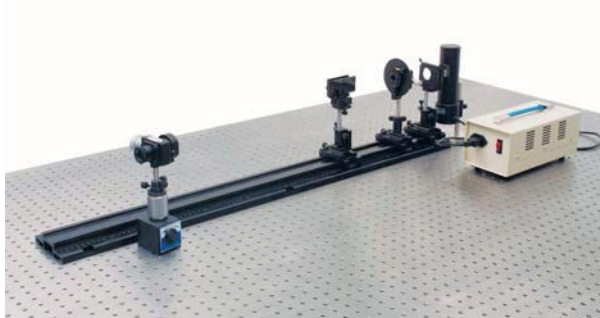

Figure 12-1

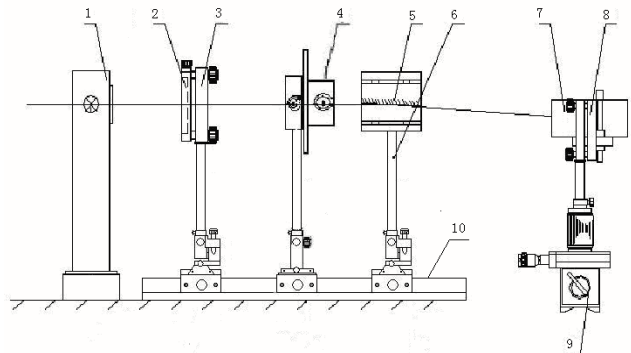

Figure 12-2

Principle

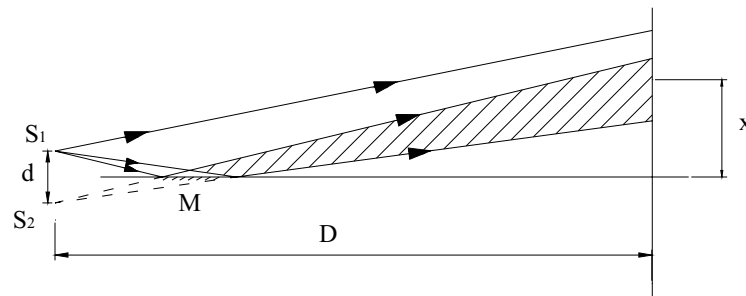

Figure 12-3

Lloyd's mirror is a simpler experiment to construct than Fresnel's mirrors. A point source S_1 is placed some distance away from a plane mirror M and close to the plane of the mirror surface, so that light is reflected at nearly grazing incidence. The coherent sources are the primary source S_1 and its virtual image S_2 by the mirror. The bisector of S_1 and S_2 then lies in the plane of the mirror surface.

Similar to Fresnel's mirrors experiment, we have the expression:

$$\lambda = \frac{d}{D} \Delta x \quad (12-1)$$

Experimental Procedures:

- 1) Refer to Figure 12-2, align all components in same height, set the distances between components around these values shown in the Figure;
- 2) Focus the aperture of the light source onto the single slit by a lens, mount Lloyd's mirror in approximately vertical;
- 3) Slowly move the Lloyd's mirror close to the optical axis from one side, let the input light sweep across the mirror. Behind the mirror, using one eye to observe the direct and the reflected beams, the slit S and its virtual image S' (by Lloyd's mirror) will be observed.
- 4) Rotate the single slit to align S and S' parallel, fix Lloyd's mirror when the interval of S and S' is about 2 mm.
- 5) Use direct measurement microscope to observe Lloyd's mirror interference pattern, and equal-interval bright/dark fringe pairs will be observed;
- 6) Measure the fringe interval Δx between two adjacent fringes using direct measurement microscope and the distance D between single slit and microscope;
- 7) To obtain the interval d between the two light sources S and S' , put a lens L_2 ($f' = 190$ mm) behind Lloyd's mirrors to image the two light sources into real images, move the direct measurement microscope to the real images plane and measure the distance between the two real images as d' . Obtain d by using Gauss formula.
- 8) Use d , Δx , D and expression of $\lambda = \frac{d}{D} \Delta x$, wavelength λ of the illumination light can be obtained.

13. Interference of Newton's Ring

Objective

To observe equal thickness interference phenomena and calculation of surface curvature by measuring interference fringe separations of Newton's Ring.

Experimental Setup (Figure 13-2)

- | | |
|-----------------------------------|-----------------------------|
| 1: Newton Ring Holder (LEPO-39) | 5: DMM Holder (LEPO-37) |
| 2: Newton Ring Assembly (LEPO-38) | 6: Sodium Lamp (LLE-2) |
| 3: Beam Splitter (5:5) | 7: Plate Holder A (LEPO-13) |
| 4: DMM with Objective | 8: Optical Rail (LEPO-54) |

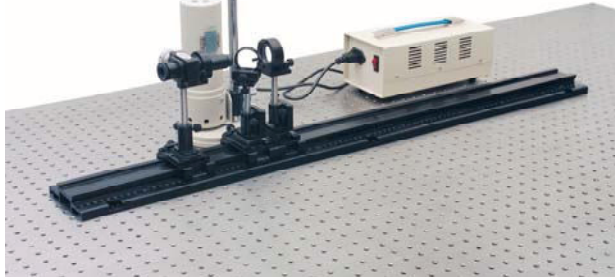

Figure 13-1

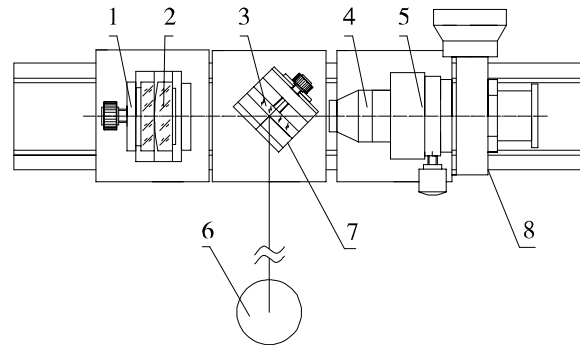

Figure 13-2

Principle

The convex surface of a long focal length lens (large radius of curvature) is placed in contact with a plane glass and clamped together. A thin film of air is formed between the spherical surface of the lens and the surface of the plane glass (Figure 13-3) and fringes called Newton's rings can be observed. If R is the radius of curvature of the convex surface, then, the thickness of the thin "air-film" h is given by

$$h = R - \sqrt{R^2 - r^2} \approx \frac{r^2}{2R} \quad (13-1)$$

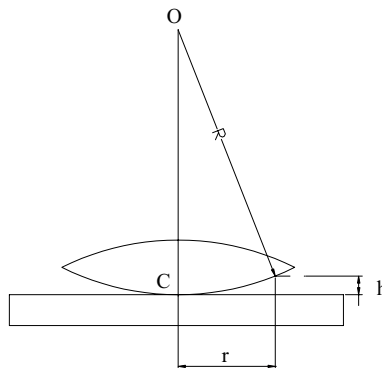

Figure 13-3

The radius of the m_{th} dark ring is given by

$$r_m = \sqrt{mR\lambda} \quad m = 0, \pm 1, \pm 2 \dots \quad (13-2)$$

It gives a way to measure the radius of curvature of the convex surface. However, very small dust particles may lift the contact point slightly above the surface of the optical flat and r_m can not be measured exactly. We can measure the radii of two rings and use below expression to calculate R .

$$R = \frac{r_m^2 - r_n^2}{m - n} \lambda \quad (13-3)$$

Experimental Procedures:

- 1) Adjust screws of the Newton's Ring assembly, get proper pressure between the flat glass and the plano-convex lens and let the contact point around the centre;
- 2) Refer to Figure 13-2, align all components in same height;
- 3) Adjust beam splitter, find interference fringes in the viewing field of the direct measurement microscope;
- 4) Measure the rings diameters using the microscope, such as from 10th to 15th rings;
- 5) Calculate surface curvature radius of the lens by using radii of any two interference rings (m_{th} and n_{th} , e.g. $m-n = 5$), based on the formula: $R = \frac{r_m^2 - r_n^2}{(m - n)\lambda}$, average all results to obtain curvature radius.

14. Fraunhofer Diffraction of Single Slit

Objective

Observation of Fraunhofer diffraction phenomena and calculation of the width of single slit.

Experimental Setup (Figure 14-2)

- | | |
|--|----------------------------------|
| 1: Sodium Lamp (LLE-2) | 6: Lens L_2 ($f'=300$ mm) |
| 2: A Single-Side Rotary Slit S_1 (LEPO-42) | 7: Two-axis Tilt Holder (LEPO-8) |
| 3: Lens L_1 ($f'=150$ mm) | 8: DMM Holder (LEPO-37) |
| 4: Two-axis Tilt Holder (LEPO-8) | 9: Eyepiece of DMM |
| 5: Single-Side Adjustable Slit S_2 (LEPO-28) | 10: Optical Rail (LEPO -54) |



Figure 14-1

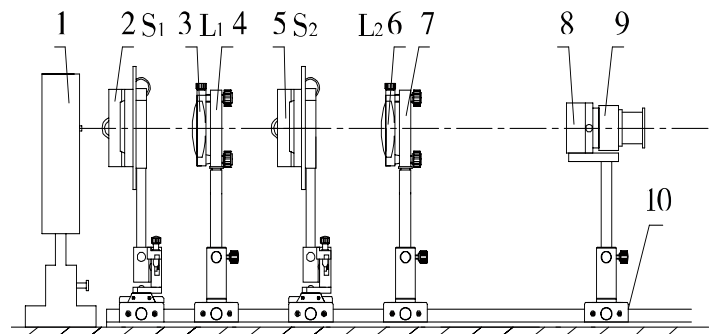

Figure 14-2

Principle

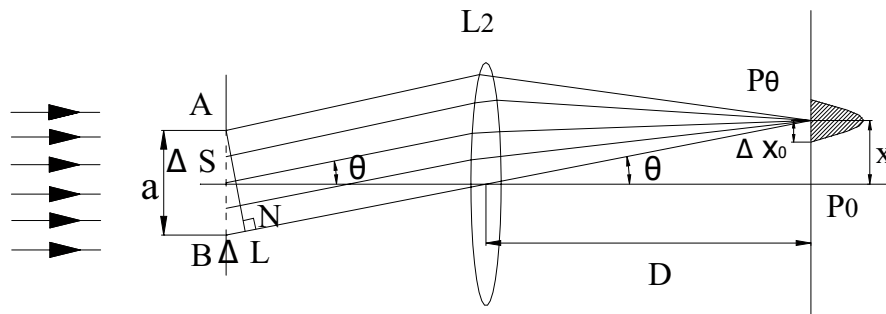

Figure 14-3

Fraunhofer diffraction is the diffraction of parallel light. The simplest explanation of Fraunhofer diffraction appears to be based on Huygens' Principle. A plane wave is incident upon a long, narrow slit and there are an infinite number of secondary sources which emit spherical waves, across the aperture. For a particular observation point, each source has a different optical path which introduces a phase relationship between the waves that are emitted across the aperture. The resultant sum becomes an integral over the aperture and a simple relationship between the "angle of diffraction" and the light intensity in the observation plane can be derived. In the observation plane we may write:

$$I = I_0 \frac{\sin^2(\beta)}{\beta^2} \quad (14-1)$$

Where, $\beta = \frac{2\pi}{\lambda} \frac{a}{2} \sin \theta$, a is the slit width.

When $\beta = n\pi$ where n is an integer, minima occur. Then, $\sin \theta = \frac{\lambda}{a}$ is the condition for the first minima. This relationship can be used to calculate the slit width.

Experimental Procedures:

- 1) Refer to Figure 14-2, align all components in same height;
- 2) Put lens L_1 behind the single slit S_1 at a distance of 150 mm (focal length of L_1), the collimated beam illuminates on another single slit S_2 ;
- 3) Put lens L_2 behind single slit S_2 to focus the diffracted light;
- 4) Aim the direct measurement microscope to the back focal plane of the lens L_2 , where, bright/dark diffraction fringes will be observed;
- 5) Measure the width of the central fringe Δx_0 using the microscope;
- 6) Calculate the slit width by $a = \frac{2\lambda f'}{\Delta x_0}$ at $\lambda = 589.3$ nm.
- 7) Directly measure the slit width using the microscope, and compare this result with the calculated result in step 6.

15. Fraunhofer Diffraction of Single Circular Aperture

Objective

To observe Fraunhofer diffraction phenomena and to calculate the aperture size.

Experimental Setup (Figure 15-2)

- | | |
|--|----------------------------------|
| 1: Sodium Lamp (LLE-2) | 5: Two-axis Tilt Holder (LEPO-8) |
| 2: $\Phi 1$ mm Aperture | 6: DMM Holder (LEPO-37) |
| 3: Multi-Pinhole Disc (LEPO-24, use 0.2-0.5 mm hole) | 7: Eyepiece of DMM |
| 4: Lens L_1 ($f' = 70$ mm) | 8: Optical Rail (LEPO-54) |



Figure 15-1

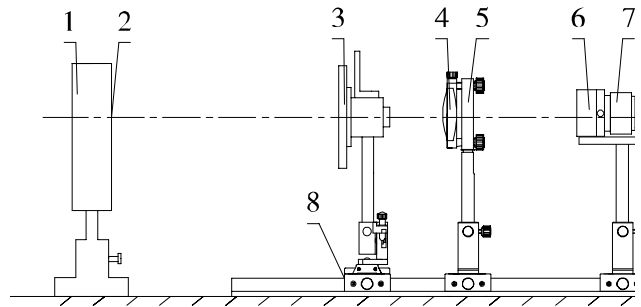

Figure 15-2

Principle

A slit will produce a diffraction pattern consisting of bright and dark fringes parallel to the slit. Different aperture shapes will produce different diffraction patterns. For example, a circular aperture produces a very bright central spot, surrounded by alternating bright and dark rings. A theoretical deduction shows that the direction of the first dark ring with respect to optical axis is

given by: $\theta = 1.22 \frac{\lambda}{a}$ (15-1) where a is the aperture diameter.

Experimental Procedures:

- 1) Refer to Figure 15-2, align all components in same height;
- 2) Select a proper small hole on the disc and put the disc far away from the light source aperture (approx. 600 mm), it is approximately satisfied with the Fraunhofer diffraction condition;
- 3) Put a lens behind the disc to focus the diffracted light;
- 4) Aim the direct measurement microscope to the back focal plane of the lens, where bright/dark diffraction rings will be observed;
- 5) Measure Airy disk diameter d using the microscope;
- 6) Calculate hole diameter by $a = \frac{1.22\lambda f'}{d}$ at $\lambda = 589.3$ nm;

- 7) Directly measure the hole diameter using the microscope, compare this result with the calculated result in step 6.

16. Fresnel Diffraction of Single Slit

Objective

Observation of Fresnel diffraction phenomena of single slit.

Experimental Setup (Figure 16-2)

- | | |
|--|--|
| 1: Laser Holder (LEPO-44) | 5: Single-side Adjustable Slit (LEPO-28) |
| 2: He-Ne Laser (LLL-2) | 6: White Screen (LEPO-14) |
| 3: Beam Expander Lens ($f' = 4.5$ mm) | 7: Optical Rail (LEPO-54) |
| 4: Two-axis Tilt Holder (LEPO-8) | |

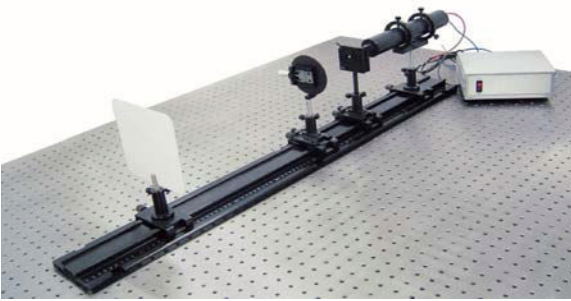

Figure 16-1

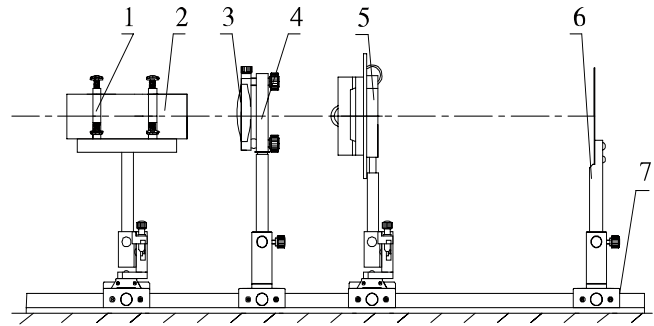

Figure 16-2

Principle

Diffraction is the bending of light waves around an object in its path. Diffraction is a kind of interference caused by the partial obstruction or lateral restriction of a transmitting wave. Because diffraction is an interference effect, diffraction will not occur if the wave is not coherent, and diffraction effects become weaker (and ultimately undetectable) as the size of obstruction is made larger and larger compared to the wavelength.



Figure 16-3

If a narrow slit with a width of a is illuminated by a plane wave (here laser beam), then, the intensity distribution observed on a screen at an angle with respect to the incident direction is

$$I(\theta) = I_0 \frac{\sin^2 \alpha}{\alpha^2}, \quad \alpha = \frac{\pi a}{\lambda} \sin \theta \quad (16-1)$$

where I_0 is the maximum intensity of central fringe of the diffraction pattern.

The intensity minima of single slit is

$$\sin \theta = m \frac{\lambda}{a} \quad m = \pm 1, \pm 2, \dots \quad (16-2)$$

Experimental Procedures:

- 1) Refer to Figure 16-2, align all components in same height;
- 2) The distance between beam expander and single-side adjustable slit is about 100mm and white screen is about 500mm from the slit;
- 3) Expand laser beam by a beam expander to obtain large divergence of the beam;
- 4) Diffraction pattern can be observed on the screen;
- 5) Change the slit width from small to large and observe the changes of the diffraction pattern.

17. Fresnel Diffraction of Single Circular Aperture

Objective

To observe Fresnel diffraction phenomena of single circular aperture.

Experimental Setup (Figure 17-2)

- 1: Laser Holder (LEPO-44)
- 2: He-Ne Laser (LLL-2)
- 3: Beam Expander Lens ($f' = 4.5$ mm)
- 4: Two-axis Tilt Holder (LEPO-8)

- 5: Multi-Pinhole Disk (LEPO-24, use 1.5 mm hole, Including holder)
- 6: White Screen (LEPO-14)
- 7: Optical Rail (LEPO-54)



Figure 17-1

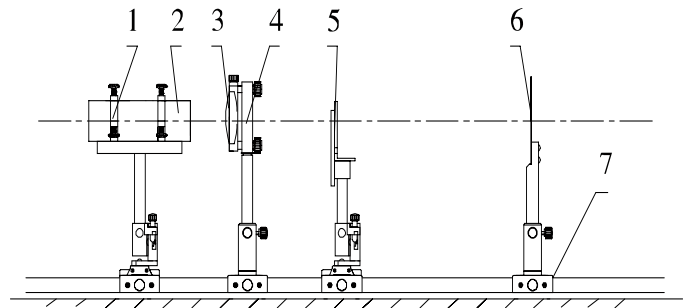

Figure 17-2

Principle

Diffraction is the bending of light waves around an object in its path. Diffraction is a kind of interference caused by the partial obstruction or lateral restriction of a transmitting wave. Because diffraction is an interference effect, diffraction will not occur if the wave is not coherent, and diffraction effects become weaker (and ultimately undetectable) as the size of obstruction is made larger and larger compared to the wavelength.



Figure 17-3

For a circular hole of diameter d , the diffraction pattern consists of concentric rings. The pattern for this intensity distribution can be calculated in the same way as for a single slit.

The condition for observing first-order minimum of intensity is:

$$\sin \theta = 1.22 \frac{\lambda}{d} \quad (17-1)$$

Where θ is the angle of observing direction with respect to the incident direction.

Experimental Procedures:

- 1) Refer to Figure 17-2, align all components in same height;
- 2) Expand laser beam by beam expander to obtain large divergence of the beam;
- 3) Diffraction pattern can be observed on the screen;
- 4) When moving the screen slowly far away from the hole, the central portion of the diffraction pattern will change from bright to dark alternatively.

18. Fresnel Diffraction of a Sharp Edge

Objective: Observation of Fresnel diffraction phenomena of a sharp edge.

Experimental Setup (Figure 18-2)

- | | |
|--|-------------------------------|
| 1: Laser Holder (LEPO-44) | 5: Razor Blade (not provided) |
| 2: He-Ne Laser (LLL-2) | 6: Plate Holder B (LEPO-19) |
| 3: Beam Expander Lens ($f' = 4.5$ mm) | 7: White Screen (LEPO-14) |
| 4: Two-axis Tilt Holder (LEPO-8) | 8: Optical Rail (LEPO-54) |

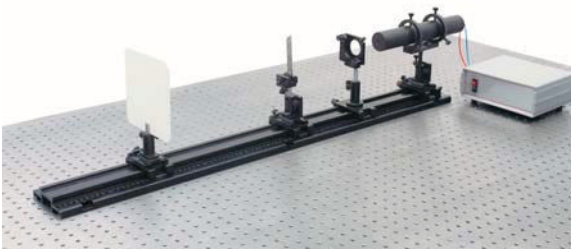

Figure 18-1

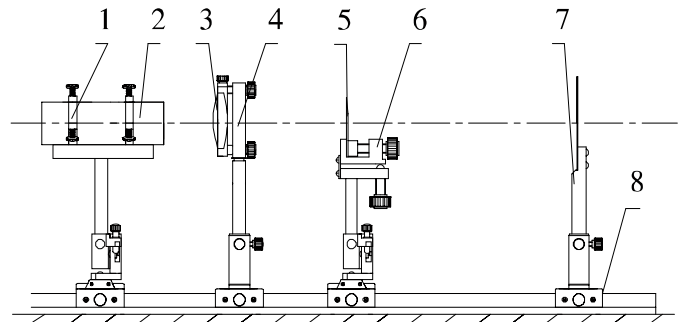

Figure 18-2

Principle

The theory of Fresnel diffraction at a straight edge is complicated than the diffraction mentioned above. It will not be addressed here. If you are interested in it, you can refer to the corresponding textbooks.

Experimental Procedures:

- 1) Refer to Figure 18-2, align all components in same height;
- 2) Expand laser beam by a beam expander to obtain large divergence of the beam;
- 3) Diffraction pattern can be observed on the screen;
- 4) Observe and analyse the diffraction pattern with respect to the theoretical prediction.

19. Analysing Polarization Status of Light Beams

Objective

Observe polarization phenomena, analyse polarization status of the input beam, generate the desired polarization status and determine the axis direction of a polarizer.

Experimental Setup (Figure 19-2)

- | | |
|--|-------------------------------|
| 1: Bromine Tungsten Lamp (LLC-4) | 6: Lloyd Mirror |
| 2: Lens ($f' = 150$ mm) | 7: Polarizer |
| 3: Two-axis Tilt Holder (LEPO-8) | 8: Polarizer Holder (LEPO-52) |
| 4: Single-side Adjustable Slit (LEPO-28) | 9: Optical Rail (LEPO-54) |
| 5: Optical Goniometer (LEPO-49) | |

* Others needed: low pressure sodium lamp (LLE-2), He-Ne laser (LLL-2), quarter-wave plate, iceland crystal rotary holder (LEPO-50), beam expander ($f' = 4.5$ mm) and Two-axis Tilt Holder (LEPO-8)



Figure 19-1

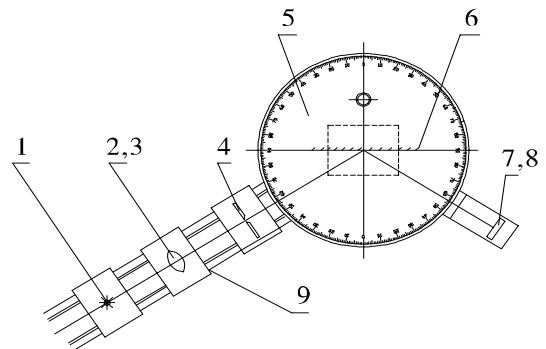

Figure 19-2

Principle

a) Brewster's Angle

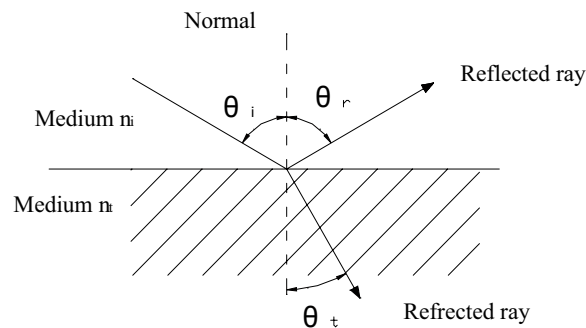

Figure 19-3

Since the reflection coefficient for light which has electric field parallel to the plane of incidence goes to zero at some angle between 0° to 90° , the reflected light at that angle is linearly polarized

with its electric field vector perpendicular to the plane of incidence. That particular angle is called Brewster's angle. The refracted light at the angle is partially polarized.

From Fresnel's equations it can be determined that the parallel reflection coefficient is zero when the sum of incident and refracted angles is 90° . The use of Snell's law gives an expression for the Brewster's angle.

When $\theta_i + \theta_t = 90^\circ$

By Snell's law

$$n_i \sin \theta_i = n_t \sin \theta_t = n_t \sin(90^\circ - \theta_i) = n_t \cos \theta_i \quad (19-1)$$

Then the Brewster's angle is:

$$\theta_B = \arctan \frac{n_t}{n_i} \quad (19-2)$$

b) Birefringence

Put an Iceland spar on a piece of printed paper, and we will see two distinct images of words. One image will remain fixed as the crystal is rotated, and that ray through the crystal is called "ordinary ray" since it behaves just as a ray through glass. However, the other image will rotate with the crystal, tracing out a small circle around the ordinary image. This ray is called "extraordinary ray". This is the phenomena of birefringence.

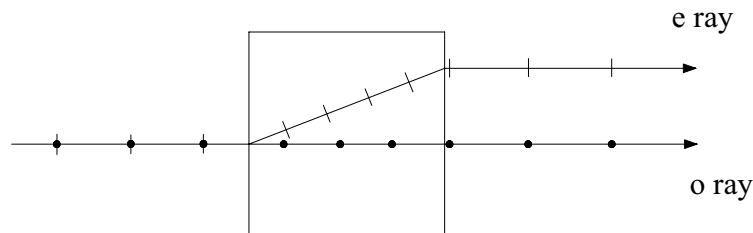

Figure 19-4

c) Malus' Law

When a light passes through a polarizer, then, passes through another polaroid, called analyser, the transmitted light intensity $I(\theta)$ leaving out of second polarizer, is given by Malus' Law

$$I(\theta) = I_0 \cos^2 \theta \quad (19-3)$$

Where I_0 is light intensity before first pass polarizer, θ is the angle of two polarizer axis.

Experimental Procedures:

- 1) Determine the polarization direction of a polarizer: the Tungsten lamp beam incidents on the surface of a glass plate at an angle close to the Brewster's angle of 57° , rotate the polarizer, directly observe the reflected beam, when it becomes the darkest, the polarizer axis lays in the plane of incident and reflection beams;
- 2) Determine the axis of $\frac{1}{2} \lambda$ wave plate: use a He-Ne laser as light source, insert a $\frac{1}{2} \lambda$ wave plate between two orthogonal polarizers with known axis directions, rotate the analyser to find darkest direction by observing a white viewing card/screen, the axis of $\frac{1}{2} \lambda$ wave plate will be either the equal-division line of the two polarizers or its perpendicular direction;

- 3) Determine the axis of $\frac{1}{4} \lambda$ wave plate: use a He-Ne laser as light source, insert the $\frac{1}{4} \lambda$ wave plate between two orthogonal polarizers with known axis directions, when the angle between polarizer and $\frac{1}{4} \lambda$ wave plate is 45° or 135° , rotate the analyser and output light intensity doesn't change, therefore the axis of $\frac{1}{4} \lambda$ wave plate will be either these directions or their perpendicular directions;
- 4) Rotate the analyser to verify Malus law;
- 5) Generate and analyse circular polarization beam and elliptical polarization beam.

20. Diffraction of a Grating

Objective

Observation of grating dispersion phenomena, grasp approach of wavelength measurement.

Experimental Setup (Figure 20-2)

- | | |
|--|---|
| 1: Mercury Lamp with Aperture Hole (LLE-1) | 8: Plate Holder B (LEPO-19) |
| 2: Lens L_1 ($f' = 50$ mm) | 9: Lens L_3 ($f' = 225$ mm) |
| 3: Two-axis Tilt Holder (LEPO-8) | 10: Lens Holder (LEPO-9) |
| 4: Single-side Adjustable Slit (LEPO-28) | 11: Eyepiece of DMM with DMM Holder (LEPO-37) |
| 5: Lens L_2 ($f' = 190$ mm) | 12: Optical Rail (LEPO-54) |
| 6: Two-axis Tilt Holder (LEPO-8) | |
| 7: Grating ($d = 1/20$ mm) | |
- *Others needed: Equilateral Prism and Grating/Prism Table (LEPO-11)

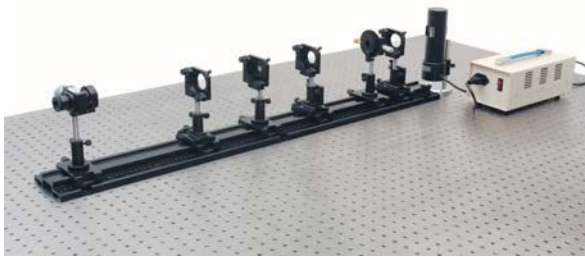

Figure 20-1

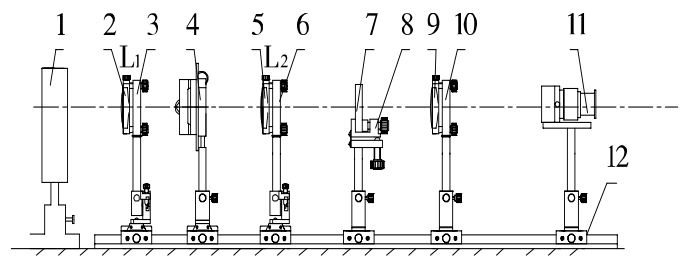

Figure 20-2

Principle

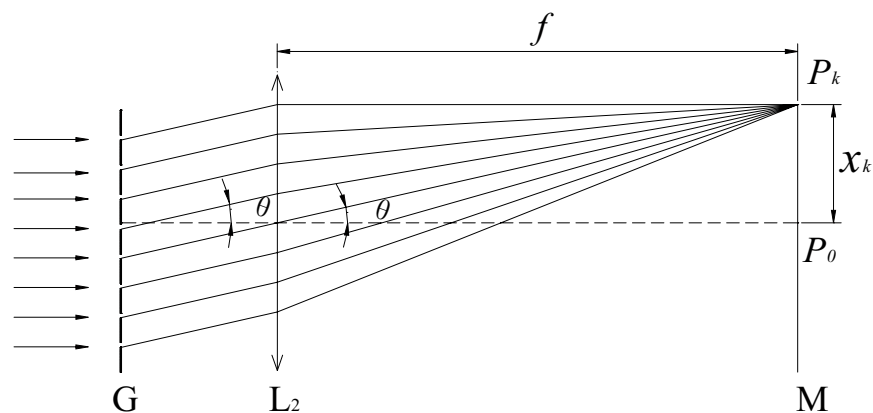

Figure 20-3

Diffraction grating is a useful optical component in spectral analysis. The working principle of a diffraction grating is much more like the principle of the single slit Fraunhofer diffraction. The grating usually consists of thousands of narrow parallel slits. So the interference fringes are very

sharp and narrow, and light beams with different wavelength will propagate in different directions. According to the grating equation, the condition for maximum intensity of each order is given by

$$d \sin \theta = k\lambda \quad (k=0, \pm 1, \pm 2 \dots) \quad (20-1)$$

Because θ is very small, so (see Figure 20-3)

$$d \frac{x_k}{f} = k\lambda \quad (k=0, \pm 1, \pm 2 \dots) \quad (20-2)$$

where d is the grating period, x_k is the distance of between k th order to zero order of the spectral line, f is the focal length of lens L_2 , λ is the wavelength of the light.

Experimental Procedures:

- 1) Refer to Figure 20-2, align all components in same height;
- 2) Set adjustable slit in vertical direction, let grating lines parallel to the slit;
- 3) Reduce slit width, move microscope eyepiece back and forth to get clear Mercury spectrum lines, eliminate viewing difference between the spectrum lines and reticle scale line in the eyepiece;
- 4) Use microscope eyepiece to measure the first order locations x_l of Mercury spectrum lines at these colours: two yellow lines, one green line and one blue line, record them as x_{1Y} , $x_{1Y'}$, x_{1G} , x_{1B} ;
- 5) Calculate the wavelengths of four spectrum lines using equation (20-2).

21. Grating Monochromator

Objective

Comprehend and grasp the working principle of grating monochromator, assemble a Littrow-type grating spectrometer.

Experimental Setup (Figure 21-2)

- | | |
|--|--|
| 1: Mercury Lamp with Aperture Hole (LLE-1) | 8a: Prism Table (LEPO-12) |
| 2: Lens L_1 ($f' = 50$ mm) | 9: Optical Rail (LEPO-54) |
| 3: Two-axis Tilt Holder (LEPO-8) | 10: Two-Axis Stages (LEPO-2) |
| 4: Single-side Adjustable Slit (LEPO-28) | 11: Grating Table (LEPO-11) |
| 5: Flat Mirror M_2 | 12: Flare grating G (1200 lines/mm) |
| 6: Two-axis Tilt Holder (LEPO-8) | 14: Single-side Rotary Adjustable Slit (LEPO-42) |
| 7: Adapter Piece (LEPO-10) | 15: Two-Axis Stages (LEPO-2) |
| 8: Spherical Mirror M_1 ($f' = 302$ mm) | |
- *Others needed: Plate Holder A (LEPO-13) and White Screen (LEPO-14)



Figure 21-1

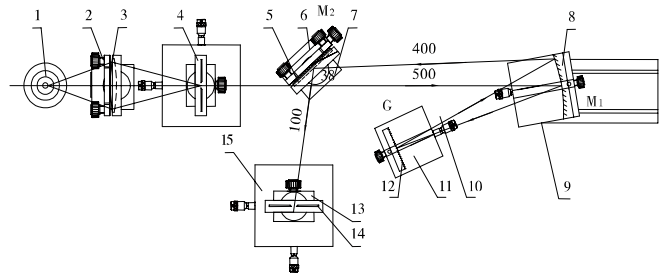

Figure 21-2

Principle

Using the characteristics of a blazed grating, we can get the spectral lines of the light source. The principle of blazed grating is almost the same as the last experiment. The blazed wavelength of k_{th} order:

$$2d \sin \theta_b = k\lambda_{kb} \quad k=1,2,3\dots \quad (21-1)$$

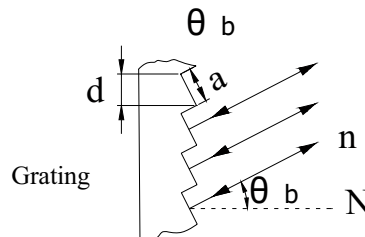

Figure 21-3

The structure of a grating monochromator is shown below.

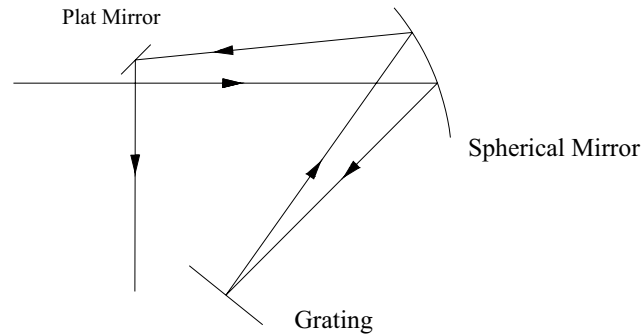

Figure 21-4

Experimental Procedures:

Note: Experiment is recommended to be carried out in a less bright environment.

- 1) Refer to Figure 21-2, align all component in same height and let the primary plane of the system parallel to the table;
- 2) Focus the light source on the adjustable slit (slit width > 0.5 mm) using a lens;
- 3) Set each component according to Figure 21-2, check the light field on M_2 , M_1 and G , make sure no part of the light path is blocked and the central portions of these components are illuminated;
- 4) Let the light beams incident on M_1 and output from M_1 have minimum intersection angle (approximately Littrow-style);
- 5) Use a white screen to find the optimal focusing position of the output spectrum, then replace the white screen with an adjustable slit at about 0.05 mm width;
- 6) Rotate the grating, spectral lines of the Mercury lamp will exit from the slit sequentially.

22. Recording and Reconstructing Holograms

Objective

Comprehend the principle of holography, learn and grasp to record the reconstruct holograms.

Experimental Setup (Figure 22-2)

- | | |
|--|---|
| 1: He-Ne Laser (LLL-2) | 12: Holographic Plate |
| 2: Laser Holder (LEPO-44) | 13: Magnetic Base (LEPO-4) |
| 3: Beam Splitter (7:3) | 14: Object |
| 4: Plate Holder A (LEPO-13) | 15: Loading Table (LEPO-21) |
| 5: Two-axis Tilt Holder (LEPO-8) | 16: Z-adjustable Post Holder (LEPO-3) |
| 6: Flat Mirror M_1 | 17: Magnetic Base (LEPO-4) |
| 7: Optical Rail (LEPO-54) | 18: Beam Expander Lens L_2 ($f' = 6.2$ mm) |
| 8: Two-axis Stages (LEPO-2) | 19: Lens Holder (LEPO-9) |
| 9: Beam Expander Lens L_1 ($f' = 4.5$ mm) | 20: Magnetic Base (LEPO-4) |
| 10: Two-axis Tilt Holder (LEPO-8) | 21: Flat Mirror M_2 |
| 11: Plate Holder B (LEPO-19) | 22: Lens Holder (LEPO-9) |



Figure 22-1

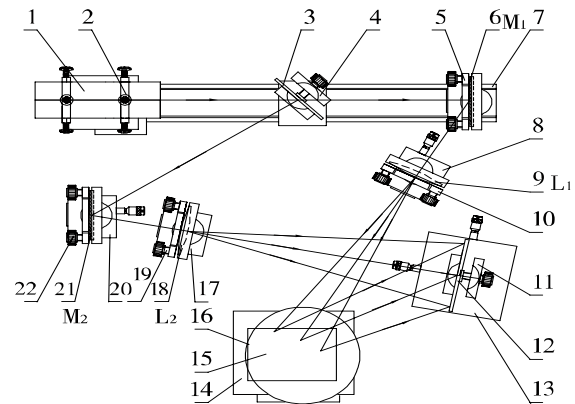

Figure 22-2

Principle

Light is a transverse electromagnetic wave, so a monochromatic light can be write as

$$x = A \cos(\omega t + \varphi - \frac{2\pi}{\lambda} r) \quad (22-1)$$

Where A is amplitude, ω is circular frequency, λ is wavelength and φ is initial phase.

Generally, camera can only record amplitude of the light reflected from the object. So the photo is a planar picture. But holography can record both the phase and amplitude of the light, thus the image is three-dimensional. And if a hologram is broken or cut up, each small portion contains information of the whole object

There are two steps in holography. The first step is to record all the information of the light reflected from the object on a holographic plate. The second step is to illuminate the hologram and reconstruct the electromagnetic wave of the object.

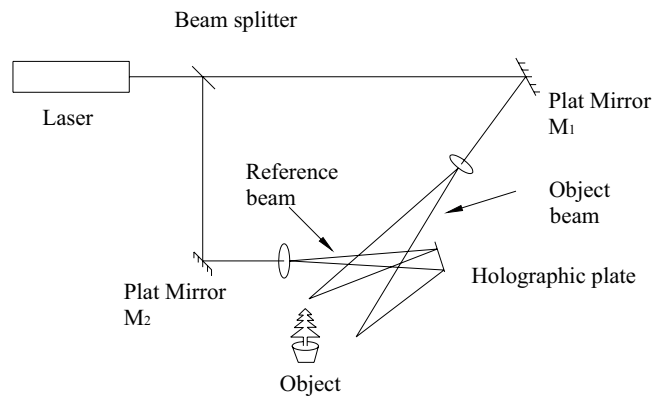

Figure 22-3

Interference pattern contains all the information of the object. When we record it, we get the holograms of the object. A laser beam is separated into two beams: one beam, called reference beam, is directed toward a holographic plate; another beam, called object beam, is reflected off the object. The object beam contains such information as location, size, shape and texture of the object. Then the two beams produce an interference pattern on the holographic plate, which is recorded in the light sensitive emulsion.

In order to reconstruct a hologram, use a laser beam to illuminate on the holographic plate at the same direction as the reference beam. Then the three-dimensional object can be observed.

Experimental Procedures:

Note: The recording of hologram in this experiment is recommended to be carried out in a vibration isolated optical table.

- 1) Refer to Figure 1-2, align all components in same height, let the primary plane of the system parallel to the table, put aside L_1 and L_2 from optical path first;
- 2) Set approximately equal optical path length for object beam and reference beam, and let their intersection angle about 30° to 40° ;
- 3) Adjust M_1 , let object beam illuminate on the central portion of the object;
- 4) Adjust M_2 , let reference beam illuminate on the central portion of the holographic plate (use a paper plate of similar size for setup);
- 5) Insert L_1 and L_2 back, adjust them so that the object beam and reference beam are still at their original centres.
- 6) Move L_2 back and forth to change the illuminating intensity of the reference beam; let the intensity ratio between reference beam and object beam about 5:1 to 10:1;
- 7) Fix all components, turn off indoors light, replace the paper plate with a holographic plate and expose the holographic plate with He-Ne laser for 10 to 15 seconds;
- 8) Develop and fix the hologram;
- 9) Put back the hologram at its original location, remove object and block object beam, observe the reconstructed object.

23. Making Holographic Gratings

Objective

Comprehend principle of holographic grating, learn and grasp the fabrication method of holographic gratings.

Experimental Setup (Figure 23-2)

- | | |
|--|------------------------------|
| 1: He-Ne Laser (LLL-2) | 8: Lens Holder (LEPO-9)) |
| 2: Laser Holder (LEPO-44) | 9: Holographic Plate |
| 3: Two-axis Tilt Holder (LEPO-8) | 10: Plate Holder A (LEPO-13) |
| 4: Beam Expander Lens L_1 ($f' = 4.5$ mm) | 11: Optical Rail (LEPO-54) |
| 5: Two-axis Tilt Holder (LEPO-8) | 12: Lens Holder (LEPO-9) |
| 6: Collimating Lens L_2 ($f' = 225$ mm) | 13: Flat Mirror M |
| 7: Beam Splitter (5:5) | 14: Two-Axis Stages (LEPO-2) |

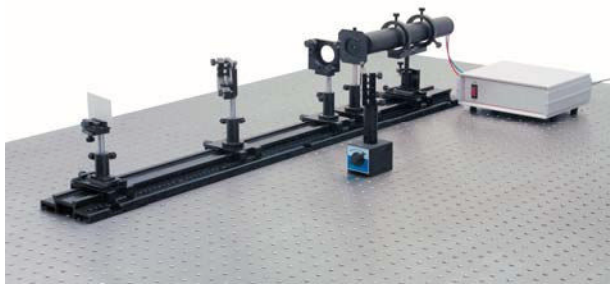

Figure 23-1

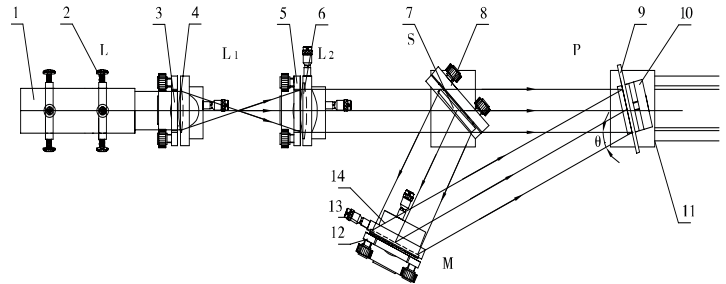

Figure 23-2

Principle

A holographic grating can be made by exposing a fine-grained light sensitive emulsion plate to the interference pattern produced by two beams of light. There are several methods which can be used to make the holographic grating: Method of Young's Double-Slit interference, Method of Fresnel's mirrors interference, Method of Lloyd's mirror interference, Method of Mach-Zehnder interference. The last three methods have a similar principle. As shown in the following Figure 23-3, the two beams strike on the holographic plate symmetrically.

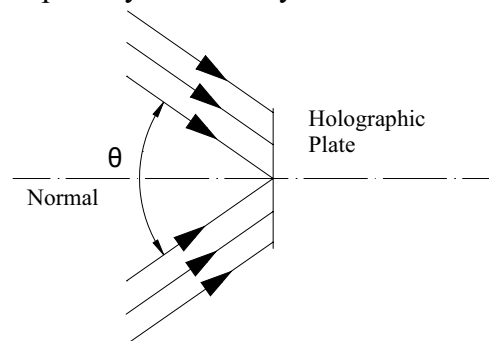

Figure 23-3

So the grating period d is given by

$$2d \sin \frac{\theta}{2} = \lambda \quad (23-1)$$

Where θ is the angle of two incident beams, λ is their wavelength.

Experimental Procedures:

- 1) Refer to Figure 23-2, align all components in same height;
- 2) Use L_1 and L_2 to construct a beam expanding system, to obtain a collimated beam with larger aperture;
- 3) Use expression (23-1) to calculate intersection angle of the two beams according to the desired grating period;
- 4) Adjust the optical path to fulfil the required angle;
- 5) Expose the holographic plate for 2 to 3 seconds;
- 6) Develop and fix the holographic grating;
- 7) Observe interference fringes under a microscope, measure fringes spacing, compare the recorded and the designed results.

24. Abbe Imaging Principle and Optical Spatial Filtering

Objective

Comprehend the basic principle of Fourier optics, grasp the concepts of optical frequency spectrum and spatial filtering.

Experimental Setup (Figure 24-2)

- | | |
|---|--|
| 1: He-Ne Laser (LLL-2) | 7. Grating (20 lines/mm) |
| 2: Laser Holder (LEPO-44) | 8: Plate Holder A (LEPO-13) |
| 3: Beam Expander Lens L_1 ($f' = 6.2$ mm or 15 mm) | 9: Fourier Transform Lens L_3 ($f' = 225$ mm) |
| 4: Two-axis Tilt Holder (LEPO-8) | 10: Lens Holder (LEPO-9) |
| 5: Collimating Lens L_2 ($f' = 190$ mm) | 11: White Screen (LEPO-14) |
| 6: Two-axis Tilt Holder (LEPO-8) | 12: Optical Rail (LEPO-54) |

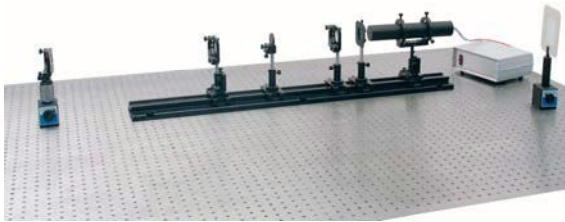

Figure 24-1

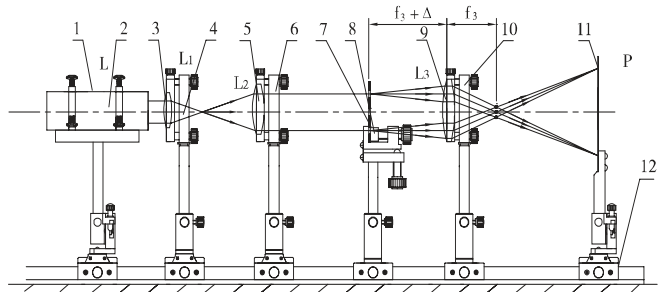

Figure 24-2

Principle

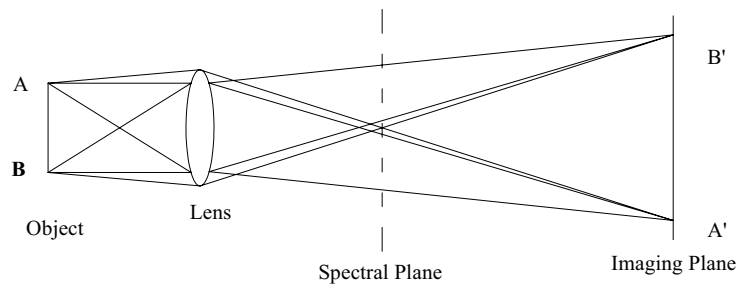

Figure 24-3

Abbe's theory assumes that the object to be imaged can be decomposed into a number of elemental gratings -- each grating diffracts light at an angle that is a function of the grating period and orientation. The diffracted beams are plane waves that are focused by a lens to diffraction patterns

of in the back focal plane of the lens. These diffraction patterns in turn act as sources of waves that propagate from the focal plane to the image plane where the image is produced. To say in a simple way, it can be considered as two steps: first step is to resolve the information, second is to synthesize the information.

Experimental Procedures:

- 1) Refer to Figure 24-2, align all components in same height;
- 2) Use L_1 and L_2 to construct a beam expanding system, to obtain a collimated beam with larger aperture and illuminate on the transmission grating (1-D grating) whose grating lines are in vertical direction;
- 3) Put a screen P away from the grating about 2 meters, move the transform lens L_3 back and forth to form a clear grating image on the screen;
- 4) Insert an adjustable slit at the back focal plane of L_3 , block all high order spectrum except zero order, check whether there are still grating lines in the image;
- 5) Adjust the slit width so that zero order and the first order pass through, observe the grating image, then remove slit, observe grating image again, compare the two cases;
- 6) Replace the transmission grating (1-D grating) with a 2-D grating, put a adjustable slit on the Fourier plane and set slit direction in vertical direction to pass the spectrum on Y axis, observe the direction of the grating lines on the image screen;
- 7) Rotate slit direction 90° to let the X axis spectrum passed, observe the direction of the grating lines on the image screen;
- 8) Further rotate slit direction 45° , observe the direction of grating lines direction on the image screen;
- 9) Put a iris diaphragm on the Fourier plane, reduce its aperture slowly, till only the zero order passes through, observe the image on screen;

25. Pseudo-Colour Encoding, Theta Modulation and Colour Composition

Objective

Comprehend concept of optical spatial filtering, grasp methods for pseudo-colour encoding and colour composition.

Experimental Setup (Figure 25-2)

1: Bromine Tungsten Lamp S (LLC-4)

2: Collimating Lens L_1 ($f'=190$ mm)

3: Two-axis Tilt Holder (LEPO-8)

4: Theta (θ) Modulation Plate

5: Plate Holder A (LEPO-13)

6: Fourier Transform Lens L_2 ($f'=150$ mm)

7: Two-axis Tilt Holder (LEPO-8)

8: Cardboard

9: Paper Clip (LEPO-51)

10: White Screen (LEPO-14)

11: Optical Rail (LEPO-54)

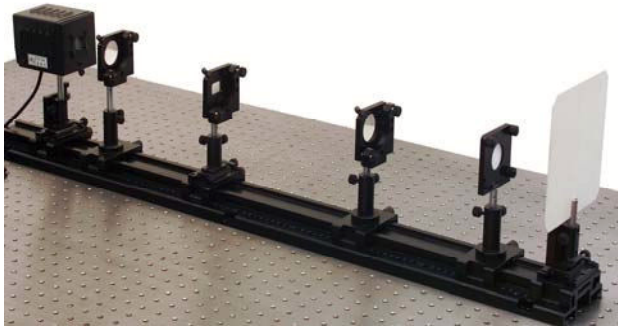

Figure 25-1

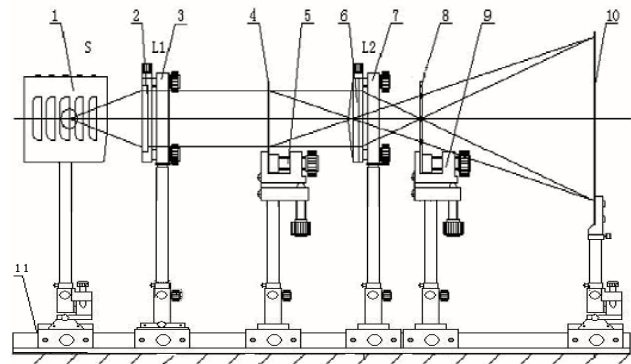

Figure 25-2

Principal

Theta modulation is the application of Abbe imaging, so the theory of theta modulation is almost the same as the Abbe imaging (refer to the principle in previous experiment). The object is a special grating which is composed of three groups grating reticles. The angle among them is 120° and they represent sky, house and ground respectively. Fourier spectrum of such a grating is shown in the middle of Figure 25-3.

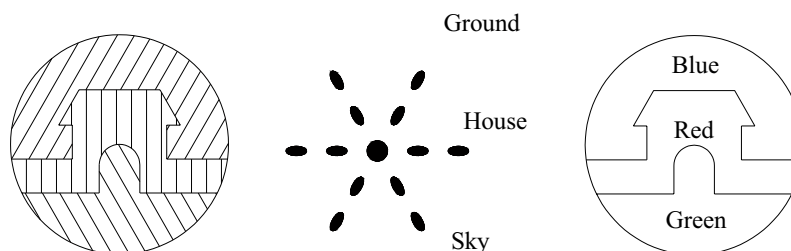

Figure 25-3

We can use the filter to select the spectra we want. We can get ‘the blue sky’, ‘the red house’ and ‘the green ground’. It is the so called pseudo-colour encoding.

Experimental Procedures:

Note: Experiment example is recommended to be carried in a less bright environment.

- 1) Refer to Figure 25-2, align all components in same height;
- 2) Put a light source at the front focal point of lens L_1 to generate a collimated beam and illuminate onto a θ modulation plate;
- 3) Put screen P away from the θ modulation plate about 0.8 meter, move the transform lens L_2 back and forth to form a clear θ modulation plate image on the screen;
- 4) Insert a filter (can be made by a cardboard) at the back focal plane of L_2 (Fourier plane), let the diffraction spectrum corresponding to the grass ground on the θ modulation plate to pass through a green filter, let the diffraction spectrum corresponding to the house on the θ modulation plate to pass through a red filter, and let the diffraction spectrum corresponding to the sky on the θ modulation plate to pass through a blue filter, observe the images which would be blue sky, red house and green grass;

26. Assembling a Michelson Interferometer and Measuring Air Refractive Index

Objective

Learn how to assemble a Michelson interferometer, grasp a method for air refractive index measurement.

Experimental Setup (Figure 26-2)

- 1: He-Ne Laser L (LLL-2)
- 2: Laser Holder (LEPO-44)
- 3: Two-axis Tilt Holder (LEPO-8)
- 4: Beam Expander Lens L_1 ($f'=4.5$ mm)
- 5: Beam Splitter BS (5:5)
- 6: Magnetic Base (LEPO-4)
- 7: White Screen H (LEPO-14) or Ground Glass Screen (LEPO-45)
- 8: Plate Holder A (LEPO-13)
- 9: Air Chamber with Pump AR
- 10: Aperture Adjustable Bar Clamp (LEPO-20)
- 11: Two-axis Tilt Holder (LEPO-8)
- 12: Flat Mirror M_1
- 13: Two-Axis Stages (LEPO-2)
- 14: Flat Mirror M_2
- 15: Lens Holder (LEPO-8)
- 16: Optical Rail (LEPO-54)



Figure 26-1

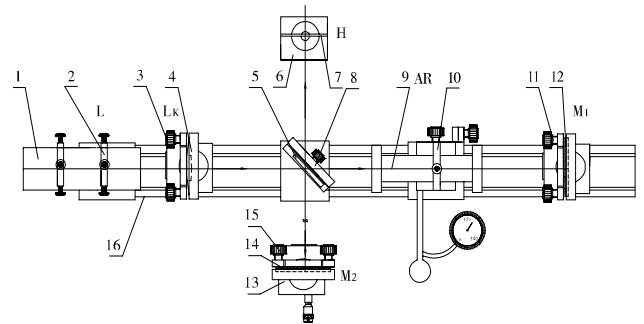

Figure 26-2

Principal

Figure 26-3 shows a schematic of a Michelson interferometer. A beam of light from the light source S strikes the beam-splitter BS , which reflects 50% of the incident light and transmits the other 50%. The incident beam is therefore split into two beams; one beam is transmitted toward the mirror M_1 , the other is reflected toward the mirror M_2 . The light reflected from M_1 transmits through the beam-splitter to the observer's eye E , and the other light reflected from M_2 is reflected by the beam-splitter BS to the observer's eye E .

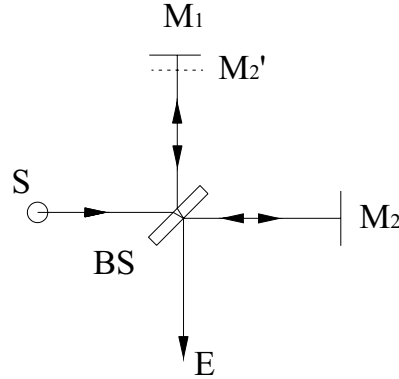

Figure 26-3

Since the beams are from the same light source, their phases are highly correlated. When a lens is placed between light source and beam-splitter, the light ray spreads out, and an interference pattern of dark and bright rings, or fringes, can be seen by observer.

If we place an air chamber in the light path between beam splitter and mirror M_2 , and then change the density of the air (by deflating the air or pumping the air), the distance of light path will change by δ . It will generate a certain number of interference fringes.

$$\delta = 2\Delta n l = N\lambda, \quad \text{so } \Delta n = N\lambda / 2l$$

Where l is length of the air chamber λ is the wavelength of the light source, N is the number of counted fringes.

The refractive index of air n is dependent upon both temperature and pressure.

For an ideal gas:

$$\frac{\rho}{\rho_0} = \frac{n-1}{n_0-1}$$

T is the absolute temperature, P is the ambient pressure. Therefore,

$$\frac{\rho}{\rho_0} = \frac{PT_0}{P_0T}$$

So we get

$$\frac{PT_0}{P_0T} = \frac{n-1}{n_0-1},$$

When temperature is constant, then

$$\Delta n = \frac{(n_0-1)T_0}{P_0T} \Delta P$$

Because $\Delta n = N\lambda / 2l$, we have

$$\frac{(n_0-1)T_0}{P_0T} \Delta P = N\lambda / 2l$$

So

$$n = 1 + \frac{N\lambda}{2l} \times \frac{P}{\Delta P}$$

Experimental Procedures:

- 1) Refer to Figure 26-2, align all components in same height;
- 2) Adjust the output of the He-Ne laser parallel and along the optical rail (beam expander lens is not inserted at this moment);
- 3) Put in a beam splitter BS at an angle of 45° with respect to beam axis, and adjust its tilt to make the two beams (transmission and reflection) parallel to table;
- 4) Adjust the tilt of mirrors M_1 and M_2 to let the beams reflected from them returning back along their incident paths, and the two beam spots on the screen H overlap together;
- 5) Insert a beam expander L_1 , finely adjust beam splitter, M_1 and M_2 , till concentric interference rings can be observed on the screen H ;
- 6) Insert an air chamber between beam splitter and M_1 , adjust it parallel to optical path, pump air into the air chamber till maximum permit pressure (40KPa) and write as ΔP ;
- 7) Slowly turn on the air valve, count the number of changing interference ring in the centre till air pressure falls to zero;
- 8) Repeat step 6, 7 several times to obtain averaged data;
- 9) Calculate the air refractive index:

$n = 1 + \frac{N\lambda}{2l} \times \frac{P}{\Delta P}$, where λ is laser wavelength, l is the length of air chamber, P is the air pressure in the laboratory, N is the number of ring change.

Laser safety and lab requirements:

Follow the corresponding laser safety guidelines based on AS/NZS 2211.1:1997 and other lab instructions about optical components etc.